



PeerlessBoilers.com

# Peerless<sup>®</sup> PureFire<sup>®</sup>

## PFC-850/1000/1500 MODBUS Application Supplement

### NOTICE

These instructions are intended as a supplement to the Peerless<sup>®</sup> PureFire<sup>®</sup> Installation, Operation and Maintenance Manual and are intended for use by a **qualified** technician.

#### A. Scope

PFC-850, PFC-1000 and PFC-1500 boilers are factory equipped with a 852IF interface adapter which allows external communication and control via the Modbus serial communication protocol. This document provides information about the data registers and values associated with the Modbus protocol.

- With the addition of a gateway device (stock code 54486), the control allows communication to BACnet<sup>™</sup> MS/TP or BACnet<sup>™</sup>/IP protocols.
- Another gateway device (stock code 54487) is required to communicate with the LonWorks<sup>®</sup> protocol. Instructions for these devices are available separately.

#### B. Specification

**Table 1: 852IF Analog Interface Specifications**

<b>Communications Protocol</b>	Modbus RTU
<b>Default Dependent Address</b>	0x01
<b>Baud Rate</b>	9600 bps
<b>Data Length</b>	8
<b>Parity</b>	None
<b>Stop Bits</b>	1
<b>Physical Layer</b>	RS485 (2-wire)
<b>Modbus 1A Connection</b>	J7-1
<b>Modbus 1B Connection</b>	J7-3

## C. Wiring 852IF

Figure 1 shows the wiring of the 852IF interface board on the PFC-850, PFC-1000 and PFC-1500 boiler. The Modbus harness (PF7030) is used to connect from the J7 connector to Modbus or an approved Modbus Gateway device.

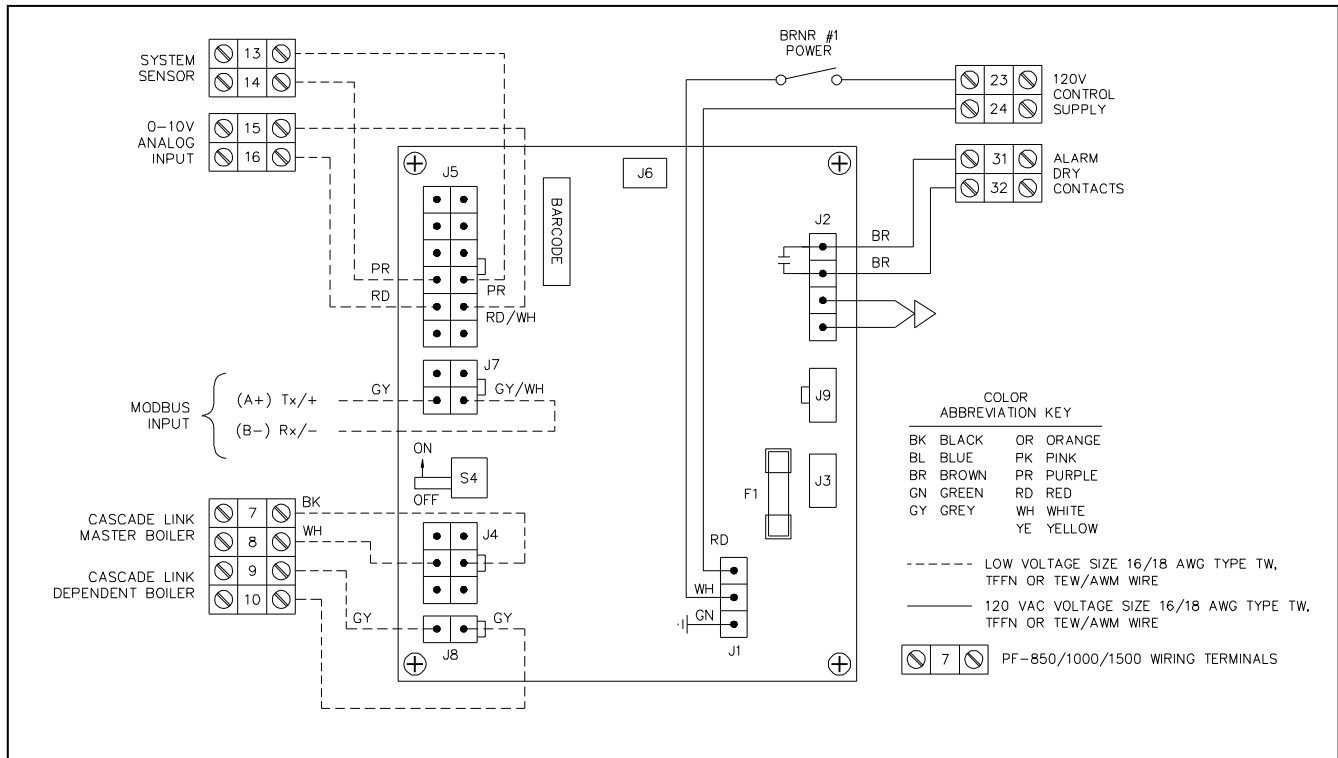

Figure 1: Wiring Schematic

## D. Modbus Address

In order to communicate with several boilers, each boiler must be given a discrete Modbus Address.

- By default, this Modbus address is 1.
- To change the Modbus address use the menu selection in the Installer menu under "Burner Settings" for "Modbus Address" right after "Cascade Address".
- The Modbus Address may be set to any value between 0 and 254.

## E. Modbus Operation

1. **Holding Registers:** Table 2 below shows the Modbus holding registers for the 852IF. Further tables detail potential values for some of these registers.

**Table 2 – 852IF Holding Registers**

Holding Register		Access*		Parameter Name	Conversion	Range
Dec.	Hex.	Read	Write			
100	0064	X	X	Modbus Units		0 = °C; 1 = °F
101	0065	X		Device Type		3 = Standalone PFC-850/1000/1500
102	0066	X		State (Managing)		See Table 3
103	0067	X		Status (Managing)		See Table 4
104	0068	X		Error Code (Managing)		See Table 5 & 6
105	0069	X		Warning Code		See Table 7
106	006A	X	X	CH Setpoint	Value/100= Temp	Temp is in C or F depending on Modbus Units
107	006B	X	X	DHW Setpoint	Value/100= Temp	Temp is in C or F depending on Modbus Units
108	006C	X	X	Not Applicable		Not Applicable
109	006D	X	X	Not Applicable		Not Applicable
110	006E	X	X	CH Mode		Table 8
111	006F	X	X	DHW Mode		Table 9
112	0070	X		Supply Temperature	Value/100= Temp	Temp is in C or F depending on Modbus Units
113	0071	X		Return Temperature	Value/100= Temp	Temp is in C or F depending on Modbus Units
114	0072	X		DHW Temperature	Value/100= Temp	Temp is in C or F depending on Modbus Units
115	0073	X		Flue Gas Temperature	Value/100= Temp	Temp is in C or F depending on Modbus Units
116	0074	X		Header Temperature	Value/100= Temp	Temp is in C or F depending on Modbus Units
117	0075	X		Firing Rate (Managing)	Auto	0 to 100%
118	0076	X		Not Applicable		
119	0077	X		Flame Current		µA
120	0078	X		Water Pressure		Not Applicable
121	0079	X		Analog In		0-10 VDC
122	007A	X		Not Applicable		Not Implemented
123	007B	X		Not Applicable		Not implemented
124	007C	X		CH Pump		0-100%
125	007D	X		DHW Pump		0-100%
126	007E	X		Successful Ignitions		Value shown x 16 = Ignition Count OK
127	007F	X		Failed Ignitions		Value Shown = Ignition Count Failed
128	0080	X		Flame Failures		Value Shown = Flame Count Failed
129	0081	X		Burner On (CH)		Burner High Hours = Burner On Time (Hours)
130	0082	X		Burner On (DHW)		Burner Med Hours = Burner DHW Hours
131	0083	X		Not Applicable		Not Implemented
150	0096	X		State (Dependent)		See Table 3
151	0097	X		Status (Dependent)		See Table 4
152	0098	X		Error Code (Dependent)		See Table 5 & 6
153	0099	X		Firing Rate (Dependent)		0-100%

2. **Temperature Input/Output:** Be sure to change the Modbus units to the appropriate value (Fahrenheit or Celsius) before reading or writing these values. When reading the values of register number 106, 107, 112, 113, 114, 115 & 116 the value must be scaled by dividing by 100. When writing the value for register numbers 106 & 107, the desired value must be multiplied by 100 before entering. This scaling is the same for both Fahrenheit and Celsius units.

- In order to write CH set point, boiler must be set to CH Mode 0 or 3.

3. **Successful Ignitions:** The value read from register 126 (Successful Ignitions) must be multiplied by 16 to get the actual value.

4. **State & Status:** The registers shown in Tables 3 & 4 give information about the current condition of the control. Note that there are “State” & “Status” values that can be read for both the Managing control and the Dependent control.

Table 3: Control State Descriptions			
STATE		State Name	Description
Dec	Hex		
0	0x00	RESET_0	Initialization
1	0x01	RESET_1	Initialization
2	0x02	STANDBY_0	Standby waiting for heat demand
3	0x03	SAFETY_ON	Ignition Sequence
4	0x04	SAFETY_OFF	Ignition Sequence
5	0x05	PRE_PURGE	Ignition Sequence
6	0x06	PRE_PURGE_1	Ignition Sequence
7	0x07	IGNIT_0	Ignition Sequence
8	0x08	IGNIT_1	Ignition Sequence
9	0x09	BURN_0	Following Boiler Demand
10	0x0A	POST_PURGE_0	Purging Combustion Chamber
11	0x0B	POST_PURGE_1	Purging Combustion Chamber
12	0x0C	PUMP_CH_0	Following CH Demand w/o Heat Input
13	0x0D	PUMP_CH_1	Post purge Pumping after CH Demand
14	0x0E	PUMP_HW_0	Following DHW Demand w/o Heat Input
15	0x0F	PUMP_HW_1	Post Purge Pumping after DHW Demand
16	0x10	ALARM_1	Error Handling
17	0x11	ERROR_CHECK	Error Handling
18	0x12	BURNER_BOOT	Controller (re)start
19	0x13	CLEAR_E2PROM_ERROR	Error Handling
20	0x14	STORE_BLOCK_ERROR	Error Handling
21	0x15	WAIT_A_SECOND	Error Handling
Table 4: Control Status Descriptions			
STATUS		Status Name	Description
Dec	Hex		
0	0x00	STANDBY	Standby waiting for Heat Demand
14	0x0E	BLOCK	Error Handling
10	0x0A	ALARM	Error Handling
15	0x0F	FROST_PROTECT	Freeze Protection Demand
16	0x10	CH	Central Heating Demand
17	0x11	RESET_STATE	Initializing
18	0x12	STORAGE	DHW Demand
19	0x13	Not Applicable	Not Applicable
20	0x14	Not Applicable	Not Applicable
21	0x15	STORE_WARM_HOLD	DHW Demand (Store Warm Hold)

5. **Error Codes:** There are two types of error codes: Blocking and Lockout. Blocking errors will prevent the control from firing the burner until the condition causing the error is corrected. Lockout errors require a manual reset at the control to resume normal boiler operation. Table 5 (below) lists Lockout error codes and their descriptions. Table 6 lists Blocking error codes and their descriptions.

Table 5: ERROR_NUMBER (Lockout Errors)			
Error Number		Error Description	Display Code
Dec	Hex		
1	0x01	Fan Speed Error - Incorrect fan speed for more than 60 seconds	A33
2	0x02	Ignition Error - 3 consecutive failed ignition attempts	A01
5	0x05	Internal Control Error - Gas Valve Relay Error	A04
6	0x06	Internal Control Error - Safety Relay Error	A06
9	0x09	Internal Control Error - RAM Error	A09
10	0x0A	Internal Control Error - E2PROM Out of Date	A12
11	0x0B	Boiler Return Temperature Higher than Supply	A50
12	0x0C	Internal Control Error - Communication Error E2PROM	A10
13	0x0D	Internal Control Error - State Error	A13
14	0x0E	Internal Control Error - ROM Error	A14
15	0x0F	Internal Control Error - Air Switch Not Open	A21
16	0x10	Internal Control Error - 15MS XRL Error	A15
17	0x11	Internal Control Error - Air Switch Not Closed	A22
18	0x12	High Temperature Limit Open	A03
19	0x13	Internal Control Error - Stack Error	A18
20	0x14	Flame Detected After Shutdown	A19
21	0x15	Flame Detected Before Ignition	A20
22	0x16	Internal Control Error - 20MS XRL Error	A16
23	0x17	Internal Control Error - 41MS Error	A32
24	0x18	Flame Failure - 3 failures during one heat call	A02
25	0x19	Flow Switch Open / Circulator Off	A23
26	0x1A	Flow Switch Closed / Circulator On	A24
27	0x1B	Internal Control Error - Flag Byte Integrity Error	A09
28	0x1C	Internal Control Error - AD HI CPL Error	A09
29	0x1D	Internal Control Error - AD LO CPL Error	A09
30	0x1E	Internal Control Error - Register Error	A09

Table 6: ERROR_NUMBER (Blocking Errors)			
Error Number		Error Description	Display Code
Dec	Hex		
31	0x1F	Internal Control Error - REFHI Too Low Error	E45
32	0x20	Internal Control Error - REFHI Too High Error	E46
33	0x21	Internal Control Error - REFLO Too Low Error	E47
34	0x22	Internal Control Error - REFLO Too High Error	E48
35	0x23	Unexpected Flame Detected	E20
36	0x24	Interlocks Open - Gas Press, LWCO or External	E31
39	0x27	High Exhaust Vent Temperature (>194° F; >90° C)	E30
40	0x28	High Return Temperature	E32
41	0x29	Blocked Condensate Drain	E26
43	0x2B	Poor Ground Connection	E24
44	0x2C	Hot & Neutral Legs Reversed	E21
45	0x2D	Frequency Error	E23
46	0x2E	Poor Ground Connection	E24
47	0x2F	Internal Control Error - WD Comm Error	E42
51	0x33	Supply Sensor Not Connected	E01
52	0x34	Return Sensor Not Connected	E02
55	0x37	DHW Sensor Not Connected	E04
57	0x39	Flue Sensor Not Connected	E05
59	0x3B	Supply Sensor Shorted	E11
60	0x3C	Return Sensor Shorted	E12
63	0x3F	DHW Sensor Shorted	E14
65	0x41	Flue Sensor Shorted	E13
66	0x42	Reset Button Error (Activated 7 times in 1 minute)	E51
67	0x43	Flap Not Closed	E52
68	0x44	Flap Not Open	E53

6. **Warning Errors:** Table 7 shows values for warning codes. Warnings are associated with temperature sensors that are either shorted or open. At the boiler these errors are indicated by a flashing burner control displays (in the electrical enclosure on the boiler).

Warning Number		Error Description	Display Code
Dec	Hex		
1	0x01	Outdoor Sensor Shorted	W01
2	0x02	DHW Sensor Not Connected	W02
3	0x03	DHW Sensor Shorted	W03
4	0x04	Flue Sensor Not Connected	W04
255	0xFF	All Sensors Operating Correctly	

7. **CH & DHW Mode:** Table 8 shows register values for central heating (CH) modes. These values are typically set upon commissioning based on the piping configuration. Table 9 shows the values for domestic hot water (DHW) modes. Again, these values are dependent on the piping and wiring configuration.

CH Mode Number		CH Mode Description	Description
Dec	Hex		
0	0x00	Indoor Thermostat	Boiler maintains a fixed, user-defined, temperature setpoint Boiler responds to thermostat demand targeting temperature setpoint
1	0x01	Thermostat and Outdoor Reset	Boiler temperature is calculated based on outdoor temperature Boiler responds to thermostat demand targeting the calculated temperature
2	0x02	Full Outdoor Reset	Boiler temperature is calculated based on outdoor temperature Boiler maintains targeted temperature calculated by the control with no thermostat input Closure of terminals #1 & #2 causes a temperature setback of 18°F
3	0x03	Permanent Demand	Boiler maintains a fixed, user-defined, temperature setpoint Boiler maintains the fixed temperature setpoint with no thermostat input Closure of terminals #1 & #2 causes a temperature setback of 18°F
4	0x04	0-10 V Input to modulate setpoint	Boiler starts if analog voltage is above 1.5 VDC Boiler temperature corresponds to an external analog input between 2 VDC (68° F) and 10 VDC (195° F)
5	0x05	Not Applicable	
6	0x06	Hydro-Air Unit	Boiler maintains a fixed, user-defined, temperature setpoint Boiler responds to thermostat demand targeting temperature setpoint

DHW Mode Number		DHW Mode Description	Description
Dec	Hex		
0	0x00	No DHW	No indirect hot water tank is connected Boiler will not respond to any input on terminals #5 & #6
1	0x01	DHW store with sensor	Indirect hot water tank is piped in the system and a tank sensor is used Boiler monitors indirect tank temperature using sensor input on terminals #5 & #6
2	0x02	DHW store with thermostat	Indirect hot water tank is piped in the system and a thermostat is used to monitor the tank temperature Boiler responds to DHW call for heat when the circuit is made between terminals #5 & #6



**PB HEAT, LLC**

131 S. CHURCH STREET • BALLY, PA 19503