



Series PSC II™

Residential Gas Boilers



- 1 Insulated Jacket
- 2 Condensate Drain
- 3 Burner Observation Port
- 4 Boiler Reset Control with Circulator Relay and Low Water Cut-off
- 5 Gas Supply
- 6 Air Inlet (available either side)
- 7 Non-Combustible Floor Pan

Series PSC II™ Boiler Features

- Up to 86% AFUE!
- Gas-fired Boiler for Natural or LP Gas
- Residential Boiler for Hot Water Systems
- 4 sizes Available; 3-6 Sections
- Cast Iron Sections—Factory Tested and Assembled with Steel Push Nipples
- Sealed Combustion (uses outside air for combustion)
- Direct Vent - Utilizes 3" AL29-4C Stainless Steel Vent Pipe for "Through-the-Wall" or Vertical "Through-the-Roof" Venting Applications
- Fully Packaged, Ready to Install

Standard Equipment

- > Boiler Reset Control with Low Water Cut-off for Increased Efficiency and Safety
- > Dependable Spark Ignition System
- > Taco 007 Circulator
- > Non-Combustible Floor Pan
- > Wall Thimble with Stainless Steel Vent Cap and Screened Vent Termination
- > 30 PSI Safety Relief Valve
- > Condensate Elbow
- > Limit Control and Drain Valve

All residential cast iron boilers include a full one-year warranty. A limited, lifetime warranty is provided for the cast iron sections of Peerless® residential hot water boilers. Visit PeerlessBoilers.com for complete details.



Technical Information

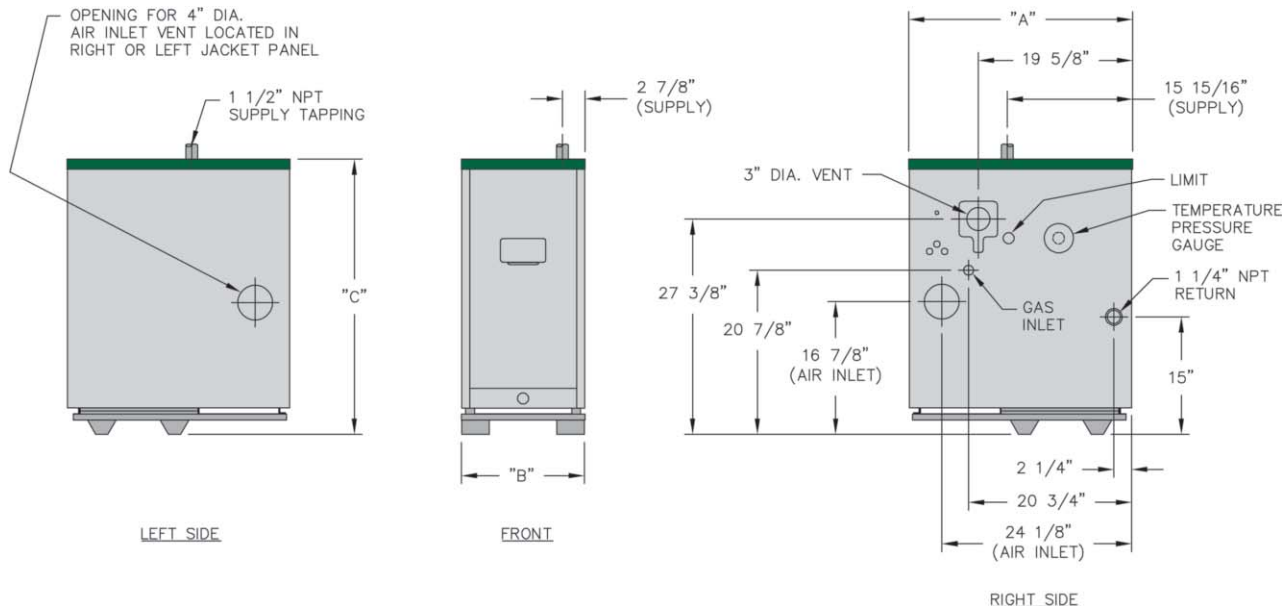

Boiler Dimensions

Boiler Model Number	Jacket Depth "A"	Jacket Width "B"	Jacket Height "C"
PSCII-03	28-1/2"	12-1/2"	35"
PSCII-04		15-7/8"	
PSCII-05		19-1/4"	
PSCII-06		22-5/8"	

Crated Dimensions & Shipping Weights

Boiler Model Number	Depth WPC	Width WPC	Height WPC	Approximate Shipping Weight (lbs.)
PSCII-03	32-3/4"	27"	40	330
PSCII-04		27"		400
PSCII-05		30-3/8"		470
PSCII-06		33-3/4"		540

Boiler Ratings

Series PSCII™ 					Water Content, gal
Boiler Model Number	Input, MBH	Heating Capacity ³ , MBH	Net Ratings Water ^{1,2} , MBH	AFUE ³ , %	
PSCII-03	65	56	48	86.0	4.72
PSCII-04	90	77	67	85.0	6.00
PSCII-05	120	102	89	85.0	7.28
PSCII-06	150	128	111	85.1	8.56

Note: Minimum Supply Gas Pressure: Standard 5 in. W.C. Natural Gas - 11 in. W.C. LP Gas.

1 Net water ratings based on an allowance of 1.15.

2 Consult factory before selecting a boiler for installations having unusual piping and pickup requirements, such as intermittent system operation, extensive piping systems, etc.

3 Heating Capacity and Annual Fuel Utilization Efficiency (AFUE) ratings are based on U.S. Government test.



PeerlessBoilers.com



Printed on Recycled Paper

PeerlessBoilers.com

CUT-PSCII R3 (1/16-3M)

Printed in U.S.A.

©2016 PB Heat, LLC. All rights reserved.