



PeerlessBoilers.com

# PUREFIRE<sup>®</sup>

## PF-300 Features and Standard Equipment

### **Performance:**

- Full Load Thermal Efficiency 96.5%
- Modulating Burner with 5:1 Turndown Capability
- Factory Equipped for Outdoor Reset Operation
- Dual Temperature Settings for Central Heating and Domestic Hot Water
- Dual Flame Sensing for Reliable Ignition
- Suitable for Firing Natural or LP Gas

### **Construction:**

- Designed, Constructed and Stamped in accordance with ASME Boiler & Pressure Vessel Code, Section IV
- Design certified for Zero Clearance to Combustible Construction
- Maximum Allowable Working Pressure: 160 PSI
- 304L Stainless Steel Heat Exchanger
- Sealed, Negative Pressure Cabinet
- Removable Jacket Panels
- Suitable for Floor or Wall Mounting
- Leveling Legs
- Factory Equipped with Boiler Service Switch
- 120 Volt Convenience Outlet

### **Exhaust/Air Intake Piping:**

- Suitable for Sealed Combustion Operation
- CPVC Vent Adapter for PVC or CPVC Pipe
- Factory Supplied Vent & Air Inlet Terminations with Screens
- Vent Temperature Sensor

### **Safety Features:**

- 30 PSIG ASME Safety Relief Valve (Loose)
- Pressure/Temperature Gauge (Loose)
- Integrated Connections for Low Water Cut Off or Flow Switch
- Manual Reset High Temperature Limit

### **Codes:**

- Design Certified to ANSI Z21.13
- CSD-1 Compliant
- Massachusetts Code Compliant

### **Control Features:**

- Plain English Status Display
- Factory Equipped for Multiple Boiler Cascade Operation
- Flame Signal Logging Capability
- Freeze Protection
- DHW Tank Warm Hold
- Ramp Delay Step Modulation
- Outdoor Sensor Included
- System Type Presets
- Temperature Boost Function
- Warm Weather Shut Down
- Anti Cycling Logic
- Limited DHW Priority
- DHW Heat Economy Circulation
- Service Notification
- System Test for Manual Control of Firing Rate
- Fault History

### **Combustion System:**

- State of the Art Fiber Burner
- Dual Flame Sensing
- High Energy Spark Ignition

### **Condensate System:**

- Built-in Condensate Trap with Neutralization
- Blocked Condensate Switch
- Highly Visible, Easy Access Condensate Collector

### **Warranty:**

- One Year Parts and Labor Warranty
- 10 Year Limited Warranty

# PEERLESS® PUREFIRE® HIGH EFFICIENCY STAINLESS STEEL BOILER

## SERIES PEERLESS® PUREFIRE® BOILER RATINGS

Boiler	Input (MBH)		Gross Output* (MBH)	Net Ratings (MBH)	Thermal Efficiency (%)
	Min	Max			
PF-300	60	300	290	252	96.5

## SERIES PEERLESS® PUREFIRE® CAPACITIES

Gas Pressure Min/Max (Inch WC)	Total Water Capacity* (Gallons)	Water Flow Rate & Pressure Drop			Total Combined Length of Air Intake & Vent (Feet)	Shipping Weight* (Lbs)
		Temperature Difference (°F)	Flow Rate* (GPM)	Pressure Drop* (Feet)		
4.5      13.5	2.60	20	29.0	11.32	200	255
		30	19.3	5.32		
		40	14.5	3.11		

## SERIES PEERLESS® PUREFIRE® ELECTRICAL RATINGS

Supply Voltage (-15%, +10%)	Frequency (±1.2 hz)	Blower		Gas Valve		Pumps		Max Total Service Current to Boiler
		Voltage (VAC)	Current (Amps)	Voltage (VAC)	Current (Amps)	Voltage (VAC)	Max. Current (Amps)	
120 VAC	60 hz	120	2.58	120	0.21	120	20.00	22.7

### Optional Equipment:

- PFA-1 Interface Adapter
  - Alarm Contacts
  - Analog Input
  - Modbus Communications
- Steel Stand Convertible for Wall Mounting
- Domestic Water Tank Temperature Sensor
- System Sensor for Multiple Boiler Operation
- Boiler Circulator
- 50 PSI Safety Relief Valve
- 100 PSI Safety Relief Valve
- 150 PSI Safety Relief Valve

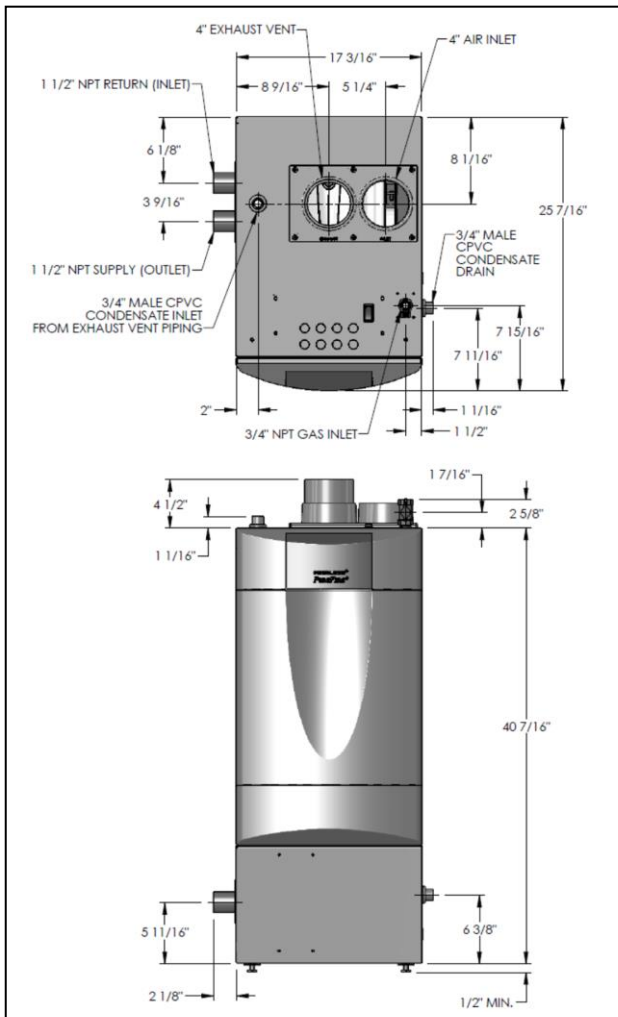

CONTROLS

