



# Peerless® *PUREFIRE*®

## PFC-460 Features and Standard Equipment

### **Performance:**

- Full Load Thermal Efficiency 95.2%
- Design Certified by SCAQMD for Low NOx Operation
- Modulating Burner with 5:1 Turndown Capability
- Factory Equipped for Outdoor Reset Operation
- Dual Temperature Settings for Central Heating and Domestic Hot Water
- Dual Flame Sensing for Reliable Ignition
- Suitable for Firing Natural or LP Gas

### **Construction:**

- Designed, Constructed and Stamped in accordance with ASME Boiler & Pressure Vessel Code, Section IV
- Design Certified for Zero Clearance to Combustible Construction
- Maximum Allowable Working Pressure: 160 PSI
- 304L Stainless Steel Heat Exchanger
- Sealed, Negative Pressure Cabinet
- Removable Jacket Panels
- Suitable for Floor or Wall Mounting\*
- Leveling Legs
- Factory Equipped with Boiler Service Switch
- 120 Volt Convenience Outlet

### **Exhaust/Air Intake Piping:**

- Suitable for Sealed Combustion Operation
- CPVC Vent Adapter for PVC or CPVC Pipe
- Factory Supplied Vent & Air Inlet Terminations with Screens
- Vent Temperature Sensor

### **Safety Features:**

- 30 PSIG ASME Safety Relief Valve (Loose)
- Pressure/Temperature Gauge (Loose)
- Integrated Connections for Low Water Cut Off or Flow Switch
- Manual Reset High Temperature Limit

### **Codes:**

- Design Certified to ANSI Z21.13
- CSD-1 Compliant
- California Emissions Compliant
- Massachusetts Plumbing Code Compliant

### **Control Features:**

- Plain English Status Display
- Factory Equipped for Multiple Boiler Cascade Operation
- Flame Signal Logging Capability
- Freeze Protection
- DHW Tank Warm Hold
- Ramp Delay Step Modulation
- Outdoor Sensor Included
- System Type Presets
- Temperature Boost Function
- Warm Weather Shut Down
- Anti Cycling Logic
- Limited DHW Priority
- DHW Heat Economy Circulation
- Service Notification
- System Test for Manual Control of Firing Rate
- Fault History

### **Combustion System:**

- High Quality Low NOx Burner
- Dual Flame Sensing
- High Energy Spark Ignition

### **Condensate System:**

- Built-in Condensate Trap with Neutralization
- Blocked Condensate Switch
- Highly Visible, Easy Access Condensate Collector

### **Warranty:**

- One Year Parts Warranty
- One Year Labor Warranty\*
- 10 Year Limited Heat Exchanger Warranty
- Available 5 & 10 Year Extended Parts & Labor Warranties
- Visit **PeerlessBoilers.com** for Complete Warranty Details

\* Purchased by PB Heat, LLC, if Product and Installer/Service Provider are Registered with Program Administrator. \_\_

# PEERLESS® PUREFIRE® HIGH EFFICIENCY STAINLESS STEEL BOILER

## PEERLESS® PUREFIRE® PFC-460 BOILER RATINGS

Boiler	Input (MBH)		Heating Capacity (MBH)	Net Ratings (MBH)	Thermal Efficiency (%)
	Min	Max			
PFC-460	92	460	430	381	95.2

## PEERLESS® PUREFIRE® PFC-460 CAPACITIES

Gas Pressure Min/Max (Inch WC)		Total Water Capacity (Gallons)	Water Flow Rate & Pressure Drop			Total Combined Length of Air Intake & Vent (Feet)	Shipping Weight (Lbs)
			Design Temp Differential (°F)	Flow Rate (GPM)	Pressure Drop (Feet)		
3.5 (N)   13.5 (N)	13.5 (N)	2.60	20	43.8	24.39	200	188
			30	29.2	11.46		
8.0 (LP)   13.5 (LP)	40		21.9	6.71			

## PEERLESS® PUREFIRE® PFC-460 ELECTRICAL RATINGS

Supply Voltage (-15%, +10%)	Frequency (±10 Hz)	Blower Current (Amps)	Gas Valve Current (Amps)	Total Control Circuit Max. Current (Amps)	Circulating Pumps Max. Current (Amps)	Total Pump Circuit Max. Current (Amps)
120 VAC	60 Hz	2.50	0.21	3.15	10.00 x 2	20.00

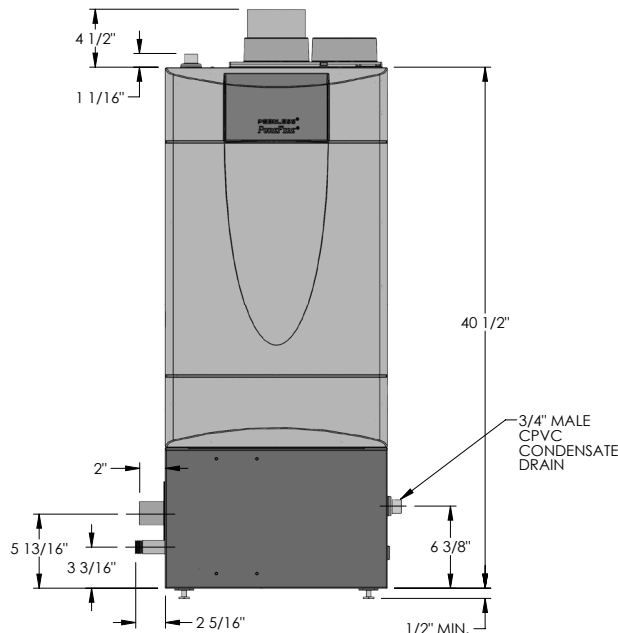
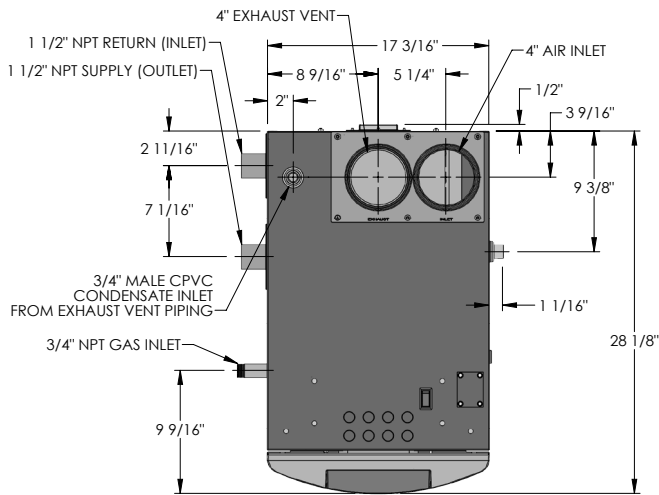

### Optional Equipment:

- PFA-1 Interface Adapter
  - Alarm Contacts
  - Analog Input
  - Modbus Communications
- 4" Concentric PVC Vent Termination
- Floor Mounted Steel Stand
- Domestic Water Tank Temperature Sensor
- System Sensor for Multiple Boiler Operation
- Boiler Circulator
- 50 PSI Safety Relief Valve
- 100 PSI Safety Relief Valve
- 150 PSI Safety Relief Valve
- Probe-type Low Water Cutoff
- Expansion Tank
- High Performance Air Vent



CONTROLS

