

PUREFIRE® PF-460 to PF-1500 & PFC-460 to PFC-1500 Gas Conversion Instructions for Propane or Natural Gas

⚠ WARNING

This conversion shall be carried out by a qualified service agency in accordance with the manufacturer's instructions and all applicable codes and requirements of the authority having jurisdiction. A qualified service agency is responsible for the proper installation of this kit. The installation is not proper and complete until the operation of the converted appliance is checked as specified in the manufacturer's instructions supplied with the kit.

⚠ WARNING

If the information in these instructions is not followed exactly, a fire, an explosion or production of carbon monoxide may result causing property damage, personal injury or loss of life.

Stop! Read these instructions or warranty will be void!

ITEMS REQUIRED FOR CONVERSION

- “Valve Converted to LP” Label [9349, (2) included]
- “Valve Converted to Natural Gas” Label [9350, (2) included]
- Boiler Conversion Label (9486, included)
- Flat Blade Screwdriver
- Combustion Analyzer with Carbon Dioxide and Carbon Monoxide Reading Capability (Testo 325-M or equivalent)

The boiler conversion must be carried out by a qualified installer or service technician in accordance with these instructions and must meet all local codes and requirements of the authority having jurisdiction. The qualified installer or technician performing this work assumes full responsibility for this conversion.

It is important to follow the conversion procedure as outlined in this document in the proper sequence. We have enclosed, for your convenience, three types of conversion labels. The labels labeled, “Valve Converted to...” are to be attached to each valve or to the inside of the boiler directly adjacent to each valve. The label that pertains to the fuel that the boiler has been changed from is to be discarded. The Boiler Conversion Label is to be placed next to the rating label on the outer jacket of the boiler.

⚠ WARNING

It is very important to follow these instructions correctly. Failure to comply may result in death or serious injury.

Note: Failure to do so will void your warranty.

STEP 1 – SECURE THE UNIT AND REVIEW THE INSTALLATION

- Turn off all power to the unit using the main disconnect switch.
- Shut off the gas supply to the boiler using the main shut off valve in the rear of the unit.
- Shut off both manual gas valves in the lower right of the boiler vestibule area.
- Make sure the gas supply is connected and check gas pressure and gas piping to the boiler to assure proper sizing for the maximum boiler firing rate.

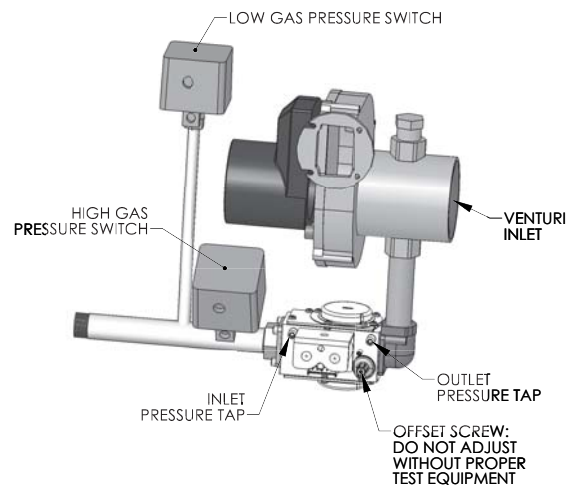

Figure 1: PF- & PFC-460

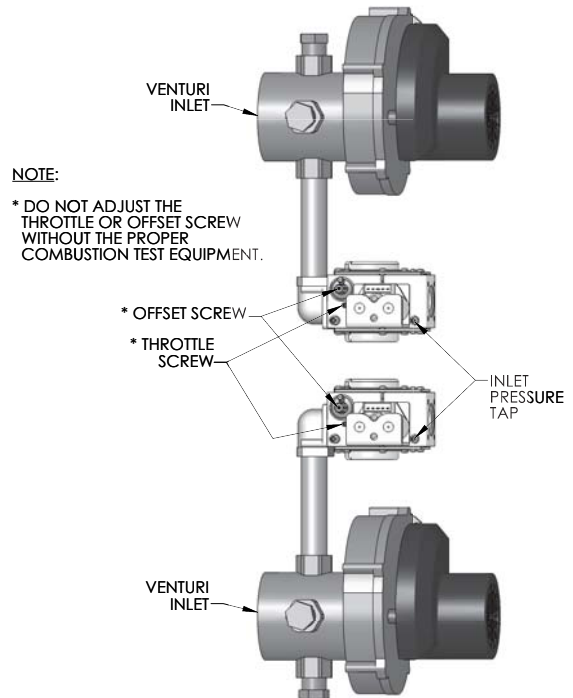

Figure 2: PF- & PFC-850 and PF- & PFC-1000

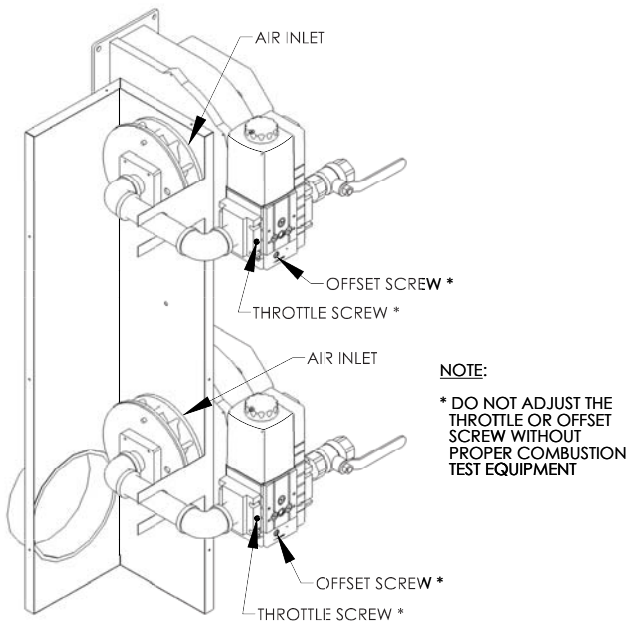

Figure 3: PF- & PFC-1500

- Contact your gas supplier to size the piping and the tank. It may also be necessary to install a 100% lockup-type gas pressure regulator of sufficient capacity to supply an adequate gas flow.

STEP 2 – TURN ON GAS AND CHECK FOR LEAKS

- Turn on the manual gas shut off valve at the rear of the unit and check for gas leaks. If leaks are found, turn off the gas and repair the leaks.
- Turn on the manual gas shut off valves on each of the burners and repeat the gas leak check.

⚠ WARNING

If you smell gas:

- Turn off the gas supply.
- Do not try to light any appliance.
- Do not touch any electrical switch: do not use any phone in your building.
- Immediately call your gas supplier from a neighbor's phone. Follow gas supplier's instructions.
- If you cannot reach your gas supplier, call the fire department. Installation and service must be performed by a qualified installer, service agency or the gas supplier.

⚠ WARNING

It is very important that this conversion is set up within the recommended combustion measurements in Step 3. Visually looking at the flame does not determine flame quality. A combustion measurement using a combustion analyzer with CO and CO₂ reading capability is the only way to assure a correct adjustment.

STEP 3 – SET UP HIGH FIRE COMBUSTION ON MASTER BURNER

- Disconnect any potential calls for heat (Terminals 1 & 2 for CH Thermostat and Terminals 3 & 4 for DHW Thermostat).
- Turn on the main power to the boiler.
- Be sure that the power switch for the master and dependent burners are on.
- Using the display for the master boiler, enter the System Test Mode:
 - Hold down the “Menu” and “Select” keys simultaneously for 10 seconds or until the display shows “Installer Menu”.
 - Press the “▼” key until the “→” indicates System Test.
 - Press the “Select” Key to choose the menu.
- Select “Maximum Power” on the System Test menu.
- Remove the plug in the test port provided on the boot tee and insert the probe of the combustion analyzer. See Figure 4 for the test port location.
- The combustion readings should agree with Table 1.

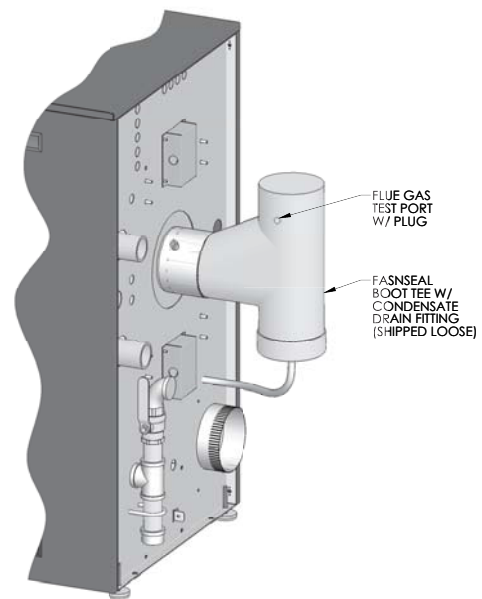

Figure 4

Table 1: Combustion Settings

	Natural Gas		Propane (LP)	
	Low Fire	High Fire	Low Fire	High Fire
Carbon Monoxide (CO)	< 50 ppm	< 100 ppm	< 50 ppm	< 100 ppm
Carbon Dioxide (CO ₂)	8.8% to 10.1%	8.5% to 9.5%	9.8% to 11.0%	9.5% to 10.5%
Excess Oxygen (O ₂)	3.4% to 5.4%	4.2% to 6.0%	4.2% to 6.0%	4.9% to 6.5%
Excess Air	17.3% to 31.0%	22.4% to 35.8%	22.4% to 35.8%	27.3% to 40.1%

- If the combustion readings do not agree with Table 1, turn the throttle screw as shown in Figure 5 and Table 2 until the readings are within the acceptable range (Table 1).
- Record the high fire combustion data on the combustion data sheet.



Figure 5

Table 2

Turning Gas Valve Throttle Screw		
	If CO is not too high	If CO is too high
If CO ₂ is too high	Turn Clockwise (-)	Turn Clockwise (-)
If CO ₂ is too low	Turn Counterclockwise (+)	Turn Clockwise (-)*

*Very high CO with low CO₂ indicates possible unburned gas due to insufficient air

STEP 4 – CHECK LOW FIRE COMBUSTION ON MASTER BURNER

- Choose “Low Power” from the System Test menu on the master burner.
- Record the low fire combustion readings after they have stabilized. If the low fire combustion readings do not agree with Table 1, turn of the boiler and contact your PB Heat Representative.
- Choose “Off” from the System Test Menu.

STEP 5 – REPEAT COMBUSTION TESTS ON THE DEPENDENT BURNER

- Repeat steps 3 and 4 for the dependent burner.
- *Note: PF- & PFC-460 does not require this step.*

STEP 6 – REPEAT COMBUSTION TESTS WITH BOTH BURNERS

- Choose “High Power” from the system test menu on both burners.
- Record combustion readings after the burners have stabilized.

- If the combined combustion readings are significantly different than those of the individual burners, contact your PB Heat Representative.

STEP 7 – EXIT FROM SYSTEM TEST

- Choose “Off” from the system test menu on both burners.
- Be sure that any openings used to obtain combustion readings are plugged.

STEP 8 – PLACE CONVERSION LABELS ON BOILER AND GAS VALVES

- Place the appropriate gas valve conversion label on the adjusted gas valve as shown.
- Fill in required information on the appropriate boiler conversion label. Place the label next to the boiler rating label.

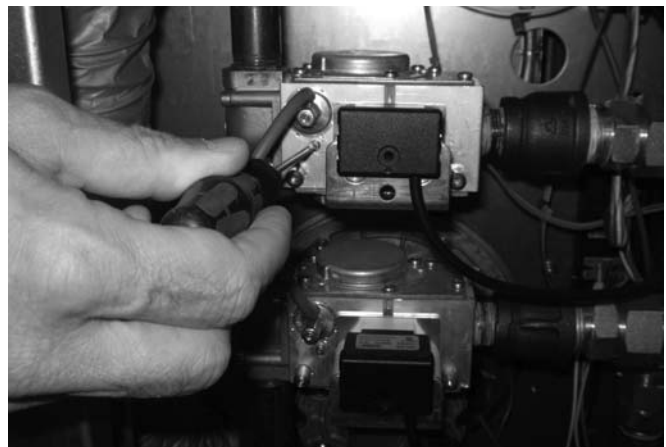

Figure 6



Figure 7

⚠ WARNING

It is extremely important that all enclosed conversion labels are placed in the proper locations shown. Not following these instructions correctly could result in death or serious injury.

Table 3

Combustion Test Record			
Installation Information			
Contact:		Phone Number:	
Service Contractor:		Fax Number:	
Contractor Address:		Email Address:	
Job Name:		Jobsite Address:	
Boiler Model:		Boiler Serial No.:	
Manufacture Date:		Conversion Date:	
Pressure Readings			
Inlet Gas Pressure – Static (in. w.c.):		Inlet Gas Pressure Drop at Startup (in. w.c.):	
High Fire Inlet Gas Pressure (in. w.c.):		Low Fire Inlet Gas Pressure (in. w.c.):	
Combustion Readings – Burner #1			
Flame Signal High Fire (μA):		Flame Signal Low Fire (μA):	
CO ₂ High Fire (%):		CO ₂ Low Fire (%):	
CO High Fire (ppm):		CO Low Fire (ppm):	
Fan Speed High Fire (RPM):		Fan Speed Low Fire (RPM):	
Combustion Readings – Burner #2			
Flame Signal High Fire (μA):		Flame Signal Low Fire (μA):	
CO ₂ High Fire (%):		CO ₂ Low Fire (%):	
CO High Fire (ppm):		CO Low Fire (ppm):	
Fan Speed High Fire (RPM):		Fan Speed Low Fire (RPM):	
Combustion Readings – Both Burners			
Flame Signal High Fire (μA):		Flame Signal Low Fire (μA):	
CO ₂ High Fire (%):		CO ₂ Low Fire (%):	
CO High Fire (ppm):		CO Low Fire (ppm):	
Fan Speed High Fire (RPM):		Fan Speed Low Fire (RPM):	
Exhaust Temperatures			
Exhaust Temp High Fire (°F):		Exhaust Temp Low Fire (°F):	



PeerlessBoilers.com

PB HEAT, LLC

131 S. CHURCH STREET • BALLY, PA 19503