



Peerless® *PUREFIRE*®

PF-200 Features and Standard Equipment

Performance:

- 95.0% Annual Fuel Utilization Efficiency (AFUE) AHRI Certified
- ENERGY STAR® Qualified
- Design Certified by SCAQMD for Low NOx Operation
- Modulating Burner with 4.7:1 Turndown Capability
- Factory Equipped for Outdoor Reset Operation
- Dual Temperature Settings for Central Heating and Domestic Hot Water
- Dual Flame Sensing for Reliable Ignition
- Suitable for Firing Natural or LP Gas

Construction:

- Designed, Constructed and Stamped in accordance with ASME Boiler & Pressure Vessel Code, Section IV
- Design Certified for Zero Clearance to Combustible Construction
- Maximum Allowable Working Pressure: 160 PSI
- 304L Stainless Steel Heat Exchanger
- Sealed, Negative Pressure Cabinet
- Removable Jacket Panels
- Suitable for Floor or Wall Mounting*
- Leveling Legs
- Factory Equipped with Boiler Service Switch
- 120 Volt Convenience Outlet

Exhaust/Air Intake Piping:

- Suitable for Sealed Combustion Operation
- CPVC Vent Adapter for PVC or CPVC Pipe
- Factory Supplied Vent & Air Inlet Terminations with Screens
- Vent Temperature Sensor

Safety Features:

- 30 PSIG ASME Safety Relief Valve (Loose)
- Pressure/Temperature Gauge (Loose)
- Integrated Connections for Low Water Cut Off or Flow Switch
- Manual Reset High Temperature Limit

Codes:

- Design Certified to ANSI Z21.13
- CSD-1 Compliant
- California Emissions Compliant
- Massachusetts Plumbing Code Compliant

Control Features:

- Plain English Status Display
- Factory Equipped for Multiple Boiler Cascade Operation
- Flame Signal Logging Capability
- Freeze Protection
- DHW Tank Warm Hold
- Ramp Delay Step Modulation
- Outdoor Sensor Included
- System Type Presets
- Temperature Boost Function
- Warm Weather Shut Down
- Anti Cycling Logic
- Limited DHW Priority
- DHW Heat Economy Circulation
- Service Notification
- System Test for Manual Control of Firing Rate
- Fault History

Combustion System:

- High Quality Low NOx Burner
- Dual Flame Sensing
- High Energy Spark Ignition

Condensate System:

- Built-in Condensate Trap with Neutralization
- Blocked Condensate Switch
- Highly Visible, Easy Access Condensate Collector

Warranty:

- One Year Parts Warranty
- One Year Labor Warranty*
- 12 Year Limited Heat Exchanger Warranty
- Available 5 & 10 Year Extended Parts & Labor Warranties
- Visit **PeerlessBoilers.com** for Complete Warranty Details

* Purchased by PB Heat, LLC, if Product and Installer/Service Provider are Registered with Program Administrator.

PEERLESS® PUREFIRE® HIGH EFFICIENCY STAINLESS STEEL BOILER

PEERLESS® PUREFIRE® PF-200 BOILER RATINGS



Boiler	Input (MBH)		Heating Capacity (MBH)	Net Ratings (MBH)	AFUE (%)
	Min	Max			
PF-200	42	199	185	161	95.0

PEERLESS® PUREFIRE® PF-200 CAPACITIES

Gas Pressure Min/Max (Inch WC)	Total Water Capacity (Gallons)	Minimum Water Flow Rate (40°F ΔT)		Total Combined Length of Air Intake & Vent (Feet)	Shipping Weight (Lbs)
		Flow Rate (GPM)	Pressure Drop (Feet)		
3.5 (N) / 13.5 (N)	1.19	9.2	5.77	200	148
8.0 (LP) / 13.5 (LP)					

PEERLESS® PUREFIRE® PF-200 ELECTRICAL RATINGS

Supply Voltage (-15%, +10%)	Frequency (±10 Hz)	Blower Current (Amps)	Gas Valve Current (Amps)	Total Control Circuit Max. Current (Amps)	Circulating Pumps Max. Current (Amps)	Total Pump Circuit Max. Current (Amps)
120 VAC	60 Hz	2.50	0.09	3.15	10.00 x 2	20.00

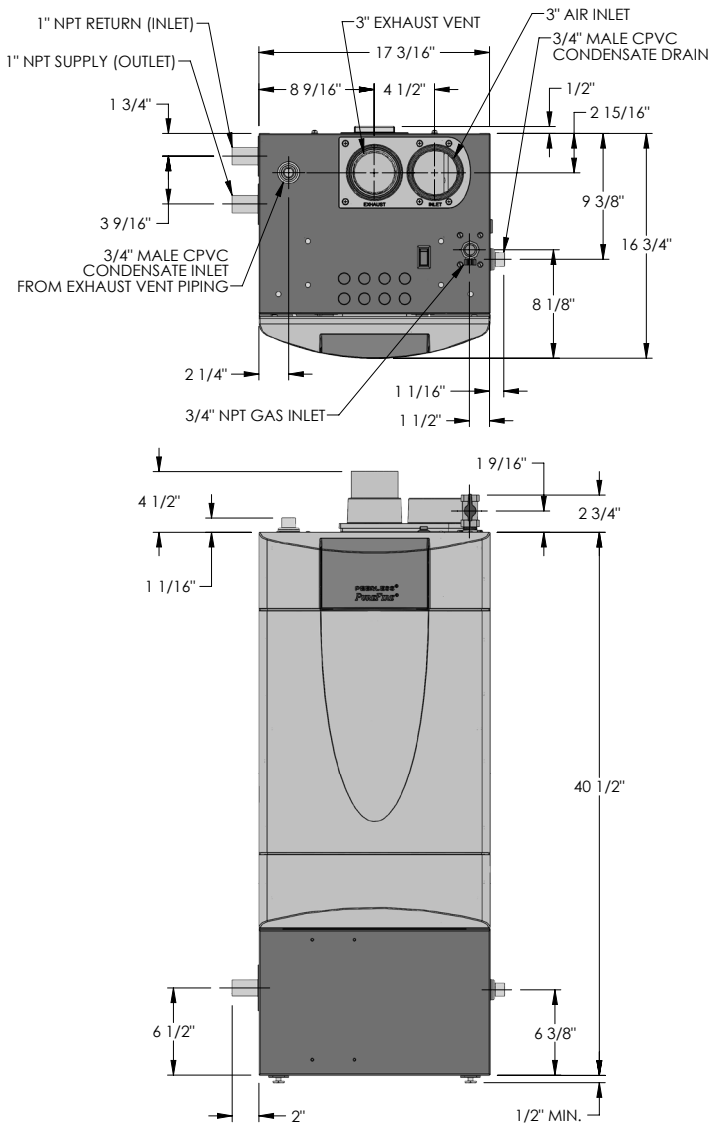

Optional Equipment:

- PFA-1 Interface Adapter
 - Alarm Contacts
 - Analog Input
 - Modbus Communications
- 3" Concentric PVC Vent Termination
- Floor Mounted Steel Stand
- PFW-200 Hot Water Boiler Conversion with Flow Switch and Piping Header Kit
- Domestic Water Tank Temperature Sensor
- System Sensor for Multiple Boiler Operation
- Boiler Circulator
- 50 PSI Safety Relief Valve
- 100 PSI Safety Relief Valve
- 150 PSI Safety Relief Valve
- Probe-Type Low Water Cutoff
- Expansion Tank
- High Performance Air Vent



CONTROLS



PF8255 R1 (03/19)
Printed in U.S.A.