



# BURNER SPEC & DATA SHEET

## **SERIES TCII™** **BECKETT MODEL "CF" BURNER** **FOR OIL**

### STANDARD EQUIPMENT

#### **CF1400 & CF2300 Burner:**

1. Burner mounted control panel with on/off control switch, power-on and fuel-on lights and terminal strip.
2. Linkageless Lo-Hi-Off operation with two-position air control.
3. Low fire hold switch.
4. Cadmium cell flame detector.
5. 15 second pre-purge/ 15 second post-purge.
6. 115 Volt/ 1 Phase/ 60 Hertz Voltage.

#### **CF2500 and CF3500 Burner:**

7. Lo-Hi-Off operation with two-position air control.
8. Low fire hold switch.
9. Visible light flame detector.
10. 30 second pre-purge/ 15 second post-purge.
11. Air flow switch.
12. 230 Volt/ 1 Phase / 60 Hertz Voltage.

### OPTIONAL EQUIPMENT

1. Control panel, burner or remote mounted, with on/off switch, control circuit fuse, and terminal strip. Also available are additional lights, alarm bell and step-down control circuit transformer.
2. Lo-Hi-Lo burner operation.
3. Air flow switches (CF1400 and CF2300).
4. Various combustion controls. Contact your local Peerless® Representative or PB Heat, LLC for availability.

**BECKETT MODEL "CF" BURNER FOR OIL**

BOILER MODEL	INPUT GPH (1)	OVERFIRE PRESSURE IN. W.C. (2)	BURNER MODEL BURNER	STANDARD COMBUSTION CONTROL	3450 RPM MOTOR HP	STANDARD MOTOR VOLTAGE	INITIAL SETTING (3)				
							HEAD	AIR DAMPER			
								LOW FIRE		HIGH FIRE	
								ELEC	MEC.	ELEC	MEC.
TCII-04	7.8	0.34	CF1400	7505P1515	1/2	115/1/60	2	35	N/A	45	N/A
TCII-05	9.5	0.35	CF2300	7505P1515	1/2	115/1/60	0	18	N/A	28	N/A
TCII-06	11.2	0.36	CF2300	7505P1515	3/4	115/1/60	3	25	N/A	35	N/A
TCII-07	13.9	0.37	CF2300	7505P1515	3/4	230/1/60	6	30	N/A	40	N/A
TCII-08	16.4	0.38	CF2500A	7505P1515	2	230/1/60	1	5	N/A	25	N/A
TCII-09	18.2	0.39	CF2500A	7505P1515	2	230/1/60	5	10	N/A	35	N/A
TCII-10	20.80	0.40	CF2500	RM7840M	2	230/1/60	7	10	N/A	45	N/A
TCII-11	22.50	0.41	CF3500	RM7840M	2	230/1/60	4	15	N/A	50	N/A
TCII-12	25.10	0.43	CF3500	RM7840M	2	230/1/60	5	15	N/A	70	N/A
TCII-13	27.50	0.44	CF3500	RM7840M	2	230/1/60	6	15	N/A	70	N/A
TCII-14	N/A	N/A	N/A	N/A	N/A	N/A	N/A	N/A	N/A	N/A	N/A
TCII-15	N/A	N/A	N/A	N/A	N/A	N/A	N/A	N/A	N/A	N/A	N/A
TCII-16	N/A	N/A	N/A	N/A	N/A	N/A	N/A	N/A	N/A	N/A	N/A
TCII-17	N/A	N/A	N/A	N/A	N/A	N/A	N/A	N/A	N/A	N/A	N/A
TCII-18	N/A	N/A	N/A	N/A	N/A	N/A	N/A	N/A	N/A	N/A	N/A

(1) Based on Commercial Standard Number 2 fuel oil with a heating value of 140,000 BTU/gal. at a maximum altitude of 2000 feet. Consult factory for higher altitudes.

(2) With 0.10 inch W.C. at flue outlet when firing at Rated Input.

(3) Start-up settings only. Final settings are to be determined using combustion analysis equipment.

BOILER MODEL	NOZZLES			OIL PRESSURE - PSIG		STANDARD FUEL UNIT	
	QTY	GPH	PATTERN	LOW FIRE	HIGH FIRE	SUNTEC GPH (4)	GEARSET GPH (4)
TCII-04	1	4.5	45 B Hago	150	300	B2TA-8851	33
TCII-05	1	5.5	60 B Hago	150	300	B2TA-8851	33
TCII-06	1	6.5	60 B Hago	150	300	B2TA-8852	39
TCII-07	1	8.0	60 B Hago	150	300	B2TA-8852	39
TCII-08	2	5.0	45 B Hago	270	270	H5PAN-C100H	79
TCII-09	2	5.5	45 B Hago	280	280	H5PAN-C100H	79
TCII-10	2	6.0	60 B Hago	300	300	H5PAN-C100H	79
TCII-11	2	6.5	60 B Del.	300	300	H5PAN-C100H	79
TCII-12	2	7.5	60 B Del.	290	290	H5PAN-C100H	79
TCII-13	2	8.0	60 B Del.	290	290	H5PAN-C100H	79
TCII-14	N/A	N/A	N/A	N/A	N/A	N/A	N/A
TCII-15	N/A	N/A	N/A	N/A	N/A	N/A	N/A
TCII-16	N/A	N/A	N/A	N/A	N/A	N/A	N/A
TCII-17	N/A	N/A	N/A	N/A	N/A	N/A	N/A
TCII-18	N/A	N/A	N/A	N/A	N/A	N/A	N/A

(4) For sizing filters, piping and remote pump sets. Not a U.L. nozzle rating.

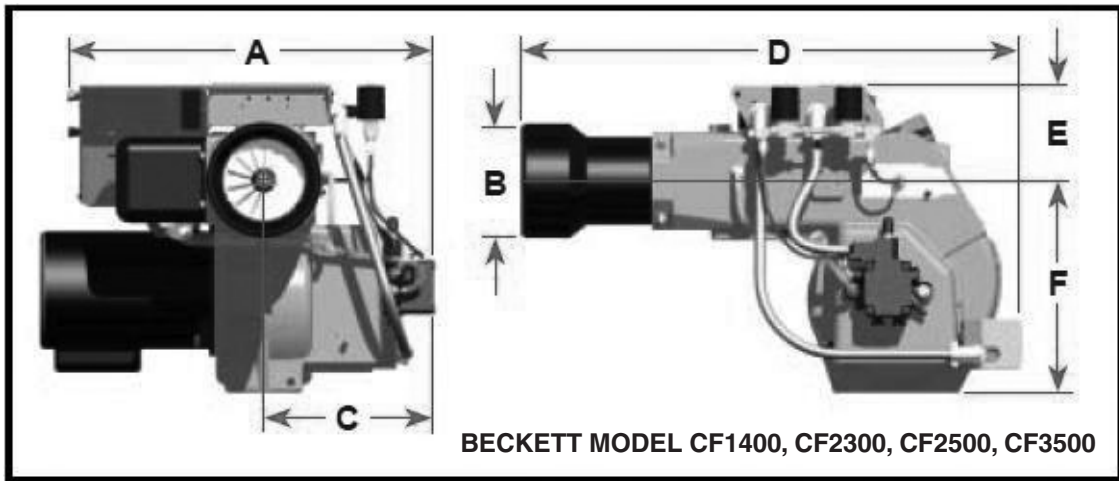

BURNER MODEL	DIMENSIONS, INCHES								RATING & SPECIFICATIONS			
	A	B		C	D		E	F	FIRING RATE MIN. (GPH)	FIRING RATE MAX. (GPH)	MOTOR SIZE (H.P.)	STANDARD MOTOR VOLTAGE
		MIN.	MAX.		MIN.	MAX.						
CF1400	18.8"	5.50"	5.88"	8.4"	25.6"	36.6"	4.9"	10.9"	4.00	13.60	1/2	120/60/1
CF2300A	19.9"	6.50"	N/A	9.6"	26.4"	38.1"	5.5"	12.7"	7.00	19.90	3/4	120/60/1
CF2500A	22.5"	6.50"	N/A	12.7"	26.8"	38.5"	5.3"	14.7"	17.00	19.90	2	208/230/60
CF2500A	22.5"	6.50"	N/A	12.7"	26.8"	38.5"	5.3"	14.7"	17.00	25.00	2	208/230/60
CF2500A	22.5"	7.88"	8.00"	12.7"	28.0"	39.0"	5.3"	14.7"	17.00	35.00	2	208/230/60

**PB HEAT, LLC**

131 S. CHURCH STREET • BALLY, PA 19503