

PEERLESS[®] PUREFIRE[®] PFW[™] SERIES

Gas Hot Water Supply Boilers

PFW-200 PFW-399



As an ENERGY STAR[®] Partner, PB Heat, LLC has determined that this product meets the ENERGY STAR guidelines for energy efficiency.

Installation, Operation & Maintenance Manual



PeerlessBoilers.com

TABLE OF CONTENTS

| | | | |
|--|-----------|--|-----------|
| USING THIS MANUAL | 1 | 7. ELECTRICAL CONNECTIONS | 29 |
| A. INSTALLATION SEQUENCE..... | 1 | A. GENERAL..... | 29 |
| B. SPECIAL ATTENTION BOXES | 1 | B. CUSTOMER CONNECTIONS..... | 29 |
| 1. PREINSTALLATION | 2 | C. INTERNAL WIRING | 29 |
| A. GENERAL..... | 2 | 8. BOILER CONTROL: INTERNAL | 32 |
| B. CODES & REGULATIONS..... | 2 | WIRING & OPERATION | |
| C. ACCESSIBILITY CLEARANCES..... | 3 | A. IGNITION SEQUENCE | 32 |
| D. COMBUSTION & VENTILATION AIR | 3 | B. USER MENU | 34 |
| E. PLANNING THE LAYOUT..... | 6 | C. INSTALLER MENU | 35 |
| 2. BOILER SET-UP | 7 | 9. START-UP PROCEDURE | 43 |
| A. GENERAL..... | 7 | A. GENERAL..... | 43 |
| B. FLOOR STANDING INSTALLATION | 7 | B. CHECK WATER PIPING | 43 |
| 3. VENTING & AIR INLET PIPING | 8 | C. CHECK GAS PIPING | 43 |
| A. GENERAL..... | 8 | D. CHECK OPERATION | 43 |
| B. APPROVED MATERIALS | 8 | E. LIGHTING & OPERATING PROCEDURES | 45 |
| C. EXHAUST VENT/AIR INTAKE | | 10. TROUBLESHOOTING | 46 |
| PIPE LOCATION | 8 | A. BLOCKING ERRORS | 46 |
| D. EXHAUST VENT/AIR INTAKE PIPE SIZING | 13 | B. LOCKING ERRORS | 46 |
| E. EXHAUST VENT/AIR INTAKE | | C. WARNING ERRORS | 50 |
| INSTALLATION | 13 | 11. MAINTENANCE | 51 |
| F. EXHAUST TAPPING FOR VENT SAMPLE..... | 14 | A. GENERAL (WITH BOILER IN USE) | 52 |
| G. BOILER REMOVAL FROM COMMON | | B. WEEKLY (WITH BOILER IN USE) | 52 |
| VENTING SYSTEM | 14 | C. ANNUALLY (BEFORE START OF HEATING | |
| 4. WATER PIPING AND CONTROLS | 15 | SEASON) | 52 |
| A. GENERAL..... | 15 | D. CONDENSATE CLEANING | |
| B. OPERATING PARAMETERS..... | 15 | INSTRUCTIONS..... | 52 |
| C. SYSTEM COMPONENTS | 15 | E. COMBUSTION CHAMBER COIL CLEANING | |
| D. SYSTEM PIPING | 17 | INSTRUCTIONS..... | 53 |
| 5. FUEL PIPING | 24 | 12. BOILER DIMENSIONS & RATINGS | 55 |
| A. GENERAL..... | 24 | 13. REPAIR PARTS | 57 |
| B. FUEL LINE SIZING..... | 24 | APPENDIX A. STATUS SCREENS | 62 |
| C. GAS SUPPLY PIPING – INSTALLATION | 24 | APPENDIX B. USER MENU | 65 |
| D. GAS SUPPLY PIPING – OPERATION | 25 | APPENDIX C. INSTALLER MENU | 67 |
| E. MAIN GAS VALVE – OPERATION..... | 25 | APPENDIX D. COMBUSTION TEST | 73 |
| 6. CONDENSATE DRAIN PIPING | 27 | RECORD | |
| A. GENERAL..... | 27 | | |
| B. CONDENSATE SYSTEM | 27 | | |
| C. CONDENSATE DRAIN PIPE MATERIAL..... | 28 | | |
| D. CONDENSATE DRAIN PIPE SIZING | 28 | | |
| E. CONDENSATE DRAIN PIPE | | | |
| INSTALLATION | 28 | | |

USING THIS MANUAL

A. INSTALLATION SEQUENCE

Follow the installation instructions provided in this manual in the order shown. The order of these instructions has been set in order to provide the installer with a logical sequence of steps that will minimize potential interferences and maximize safety during boiler installation.

B. SPECIAL ATTENTION BOXES

Throughout this manual special attention boxes are provided to supplement the instructions and make special notice of potential hazards. The definition of each of these categories, in the judgement of PB Heat, LLC. are as follows:

DANGER

Indicates a hazardous situation, which, if not avoided, will result in death or serious injury and major property damage.

WARNING

Indicates a hazardous situation, which, if not avoided, could result in death or serious injury and major property damage.

CAUTION

Indicates a hazardous situation, which, if not avoided, could result in minor or moderate injury, and minor property damage.

NOTICE

Indicates special attention is needed, not related to personal injury or property damage.

1. PREINSTALLATION

A. GENERAL

1. *PureFire*® boilers are supplied completely assembled as packaged boilers. The package should be inspected for damage upon receipt and any damage to the unit should be reported to the shipping company and wholesaler. This boiler should be stored in a clean, dry area.
2. Carefully read these instructions and be sure to understand the function of all connections prior to beginning installation. Contact your PB Heat, LLC Representative for help in answering questions.
3. This boiler must be installed by a qualified contractor. The boiler warranty may be voided if the boiler is not installed correctly.

B. CODES & REGULATIONS

1. Installation and repairs are to be performed in strict accordance with the requirements of state and local regulating agencies and codes dealing with boiler and gas appliance installation.
2. In the absence of local requirements the following should be followed:
 - a. ASME Boiler and Pressure Vessel Code, Section IV - "Heating Boilers"
 - b. ASME Boiler and Pressure Vessel Code, Section VI - "Recommended Rules for the Care and Operation of Heating Boilers"

WARNING

Liquefied Petroleum (LP) Gas or Propane is heavier than air and, in the event of a leak, may collect in low areas such as basements or floor drains. The gas may then ignite resulting in a fire or explosion.

- c. ANSI Z223.1/NFPA 54 - "National Fuel Gas Code"
 - d. ANSI/NFPA 70 - "National Electrical Code"
 - e. ANSI/NFPA 211 - "Chimneys, Fireplaces, Vents and Solid Fuel Burning Appliances"
3. Where required by the authority having jurisdiction, the installation must conform to the Standard for Controls and Safety Devices for Automatically Fired Boilers, ANSI/ASME CSD-1.

****Please read if installing in Massachusetts****

Massachusetts requires manufacturers of Side Wall Vented boilers to provide the following information from the Massachusetts code:

- A hard wired carbon monoxide detector with an alarm and battery back-up must be installed on the floor level where the gas equipment is to be installed AND on each additional level of the dwelling, building or structure served by the side wall horizontal vented gas fueled equipment.
- In the event that the side wall horizontally vented gas fueled equipment is installed in a crawl space or an attic, the hard wired carbon monoxide detector with alarm and battery back-up may be installed on the next adjacent floor level.
- Detector(s) must be installed by qualified licensed professionals.
- APPROVED CARBON MONOXIDE DETECTORS: Each carbon monoxide detector shall comply with NFPA 720 and be ANSI/UL 2034 listed and IAS certified.
- SIGNAGE: A metal or plastic identification plate shall be permanently mounted to the exterior of the building at a minimum height of eight (8) feet above grade directly in line with the exhaust vent terminal for the horizontally vented gas fueled heating appliance or equipment. The sign shall read, in print size no less than one-half (1/2) inch in size, **"GAS VENT DIRECTLY BELOW. KEEP CLEAR OF ALL OBSTRUCTIONS"**.
- EXEMPTIONS to the requirements listed above:
 - The above requirements do not apply if the exhaust vent termination is seven (7) feet or more above finished grade in the area of the venting, including but not limited to decks and porches.
 - The above requirements do not apply to a boiler installed in a room or structure separate from the dwelling, building or structure used in whole or in part for residential purposes.
- This boiler installation manual shall remain with the boiler at the completion of the installation.

See the latest edition of Massachusetts Code 248 CMR for complete verbiage and also for additional (non-vent related) requirements (248 CMR is available online).

If your installation is NOT in Massachusetts, please see your authority of jurisdiction for requirements that may be in effect in your area. In the absence of such requirements, follow the National Fuel Gas Code, ANSI Z223.1/NFPA 54 and/or CAN/CSA B149.1, Natural Gas and Propane Installation Code.

C. ACCESSIBILITY CLEARANCES

1. The *PureFire*® boiler is certified for closet installations with zero clearance to combustible construction. In addition, it is design certified for use on combustible floors.
2. Figure 1.1 shows the minimum recommended clearances to allow reasonable access to the boiler for Models PFW-200 and PFW-399. However, local codes or special conditions may require greater clearances.

D. COMBUSTION AND VENTILATION AIR

1. The *PureFire*® boiler is designed for operation with combustion air piped directly to the boiler from outside the building (sealed combustion). Combustion air may be supplied from within the building only if adequate combustion air and ventilation air is provided in accordance with the National Fuel Gas Code or applicable provisions of the local building code. Subsections 3 through 10 as follows are based on the National Fuel Gas Code requirements.
2. If the combustion air is piped directly to the boiler from outside the building, no additional combustion or ventilation air is required. Otherwise, follow the National Fuel Gas Code recommendations summarized in subsections 3 through 10.

3. Required Combustion Air Volume: The total required volume of indoor air is to be the sum of the required volumes for all appliances located within the space. Rooms communicating directly with the space in which the appliances are installed and through combustion air openings sized as indicated in Subsection 3 are considered part of the required volume. The required volume of indoor air is to be determined by one of two methods.
 - a. Standard Method: The minimum required volume of indoor air (room volume) shall be 50 cubic feet per 1000 BTU/Hr (4.8 m3/kW). This method is to be used if the air infiltration rate is unknown or if the rate of air infiltration is known to be greater than 0.6 air changes per hour. As an option, this method may be used if the air infiltration rate is known to be between 0.6 and 0.4 air changes per hour. If the air infiltration rate is known to be below 0.4 then the Known Air Infiltration Rate Method must be used. If the building in which this appliance is to be installed is unusually tight, PB Heat, LLC recommends that the air infiltration rate be determined.
 - b. Known Air Infiltration Rate Method:

where:

$$\text{Required Volume}_{\text{fan}} = \frac{15 \text{ ft}^3}{\text{ACH}} \left(\frac{I_{\text{fan}}}{1000^{\text{Btu/hr}}} \right)$$

I_{fan} = Input of the fan assisted appliances assisted in Btu/hr

ACH = air change per hour (percent of the volume of the space exchanged per hour, expressed as a decimal)

Note: These calculations are not to be used for infiltration rates greater than 0.60 ACH.

4. Indoor Air Opening Size and Location: Openings

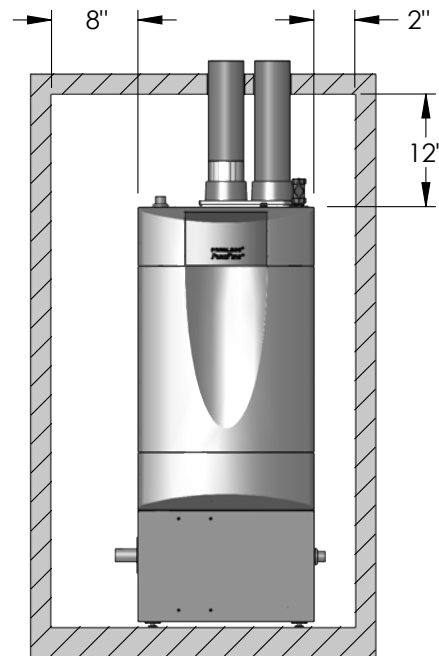
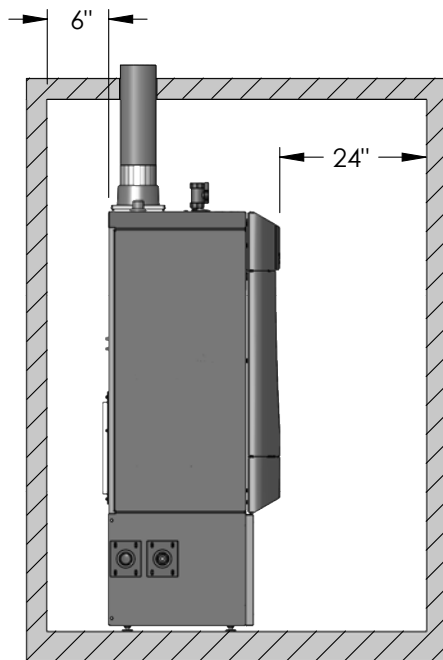

Figure 1.1: Minimum Accessibility Clearances – PFW-200 & PFW-399

connecting indoor spaces shall be sized and located as follows:

- a. **Combining Spaces on the Same Floor:** Provide two permanent openings communicating with additional spaces that have a minimum free area of 1 in² per 1000 Btu/hr (22 cm² per 1000 W) of the total input rating of all gas fired equipment but not less than 100 in² (645 cm²). One opening is to begin within 12 inches (305 mm) from the top of the space and the other is to begin within 12 inches (305 mm) from the floor. The minimum dimension of either of these openings shall be 3 inches (76 mm), see Figure 1.2 for an illustration of this arrangement.
- b. **Combining Spaces on Different Floors:** Provide one or more permanent openings communicating with

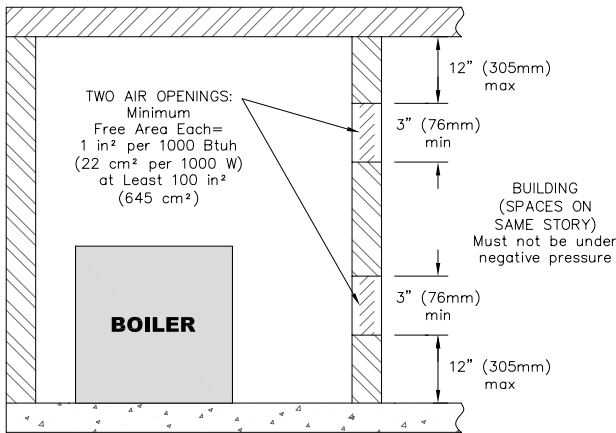

Figure 1.2: Air Openings – All Air from Indoors on the Same Floor

additional spaces that have a total minimum free area of 2 in² per 1000 Btu/hr (44 cm² per 1000 W) of total input rating of all equipment, see Figure 1.3 for an illustration of this arrangement.

5. Outdoor Combustion Air: Outdoor combustion air is to

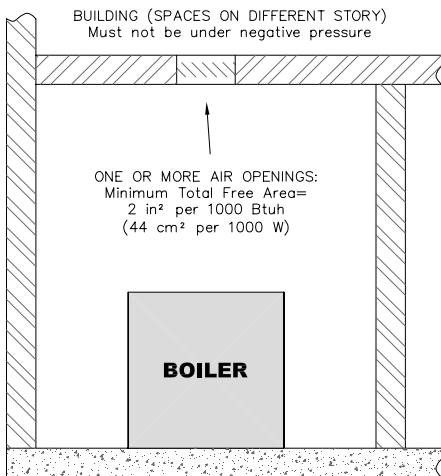

Figure 1.3: Air Openings – All Air from Indoors on Different Floors

be provided through one or two permanent openings. The minimum dimension of these air openings is 3 inches (76 mm).

- a. **Two Permanent Opening Method:** Provide two permanent openings. One opening is to begin within 12 inches (305 mm) of the top of the space and the other is to begin within 12 inches (305 mm) of the floor. The openings are to communicate directly or by ducts with the outdoors or with spaces that freely communicate with the outdoors. The size of the openings shall be determined as follows:
 - i. Where communicating directly or through vertical ducts with the outdoors each opening shall have a minimum free area of 1 in² per 4000 Btu/hr (22 cm² per 4000 W) of total input rating for all equipment in the space, see Figure 1.4 for openings directly communicating with the outdoors or Figure 1.5 for openings connected by ducts to the outdoors.
 - ii. Where communicating with the outdoors through horizontal ducts, each opening shall have a minimum free area of 1 in² per 2000 Btu/hr (22 cm²

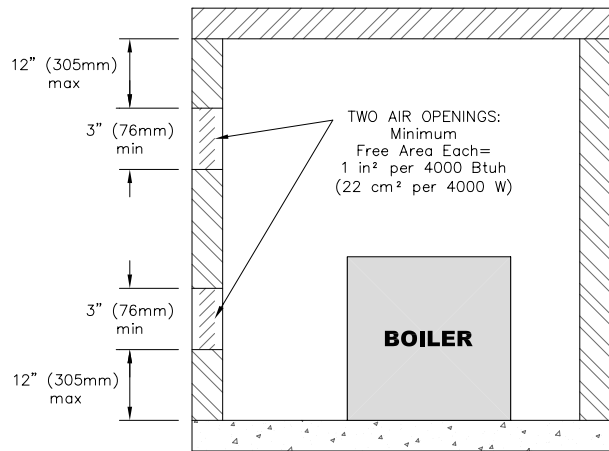

Figure 1.4: Air Openings – All Air Directly from Outdoors

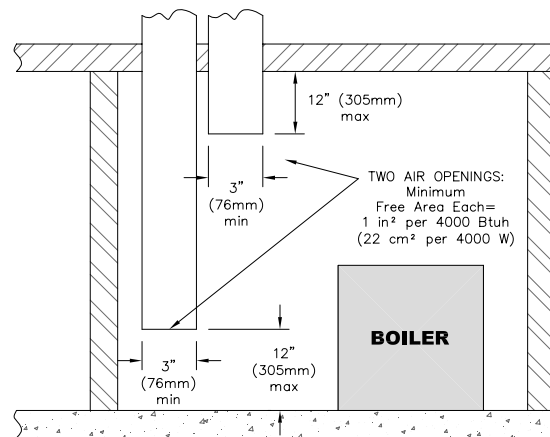

Figure 1.5: Air Openings – All Air from Outdoors through Vertical Ducts

per 2000 W) of total rated input for all appliances in the space, see Figure 1.6.

- b. **One Permanent Opening Method:** Provide one permanent opening beginning within 12 inches (305 mm) of the top of the space. The opening

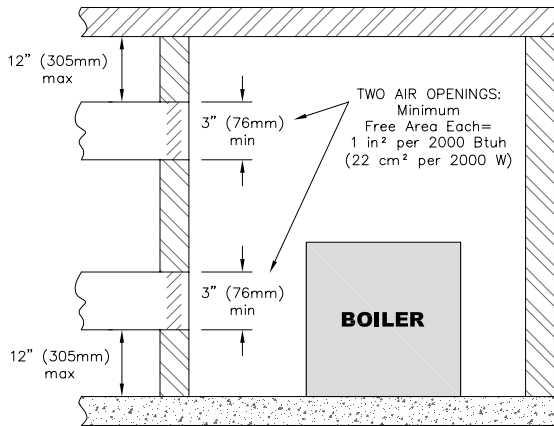

Figure 1.6: Air Openings – All Air from Outdoors through Horizontal Ducts

shall communicate directly with the outdoors, communicate through a vertical or horizontal duct, or communicate with a space that freely communicates with the outdoors. The opening shall have a minimum free area of 1 in² per 3000 Btu/hr of total rated input for all appliances in the space and not less than the sum of the cross-sectional areas of all vent connectors in the space. The gas-fired equipment shall have clearances of at least 1 inch (25 mm) from the sides and back and 6 inches (150 mm) from the front of the appliance, see Figure 1.7 for this arrangement.

- 6. **Combination Indoor and Outdoor Combustion Air:** If the required volume of indoor air exceeds the available

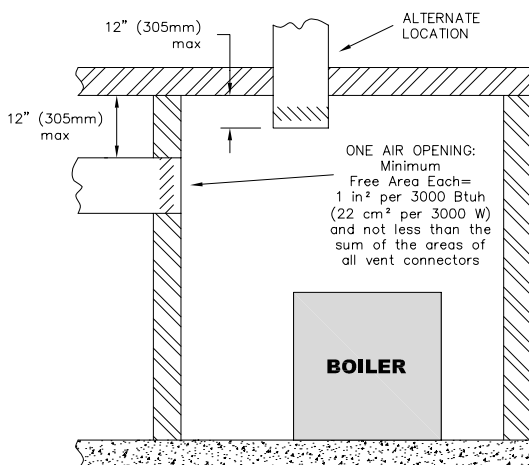

Figure 1.7: Air Openings – All Air from Outdoors through One Opening

indoor air volume, outdoor air openings or ducts may be used to supplement the available indoor air provided:

- a. The size and location of the indoor openings comply with Subsection 3.
- b. The outdoor openings are to be located in accordance with Subsection 4.
- c. The size of the outdoor openings are to be sized as follows:

where:

A_{req} = minimum area of outdoor openings.
 A_{full} = full size of outdoor openings calculated in accordance with Subsection 4.
 V_{avail} = available indoor air volume
 V_{req} = required indoor air volume

- 7. **Engineered Installations:** Engineered combustion air installations shall provide an adequate supply of combustion, ventilation, and dilution air and shall be approved by the authority having jurisdiction.
- 8. **Mechanical Combustion Air Supply:**
 - a. In installations where all combustion air is provided by a mechanical air supply system, the combustion air shall be supplied from the outdoors at the minimum rate of 0.35 ft³/min per 1000 Btu/hr (0.034 m³/min per 1000 W) of the total rated input of all appliances in the space.
 - b. In installations where exhaust fans are installed, additional air shall be provided to replace the exhaust air.
 - c. Each of the appliances served shall be interlocked to the mechanical air supply to prevent main burner operation when the mechanical air supply system is not in operation.
 - d. In buildings where the combustion air is provided by the mechanical ventilation system, the system shall provide the specified combustion air rate in addition to the required ventilation air.
- 9. **Louvers & Grills:**
 - a. The required size of openings for combustion, ventilation, and dilution air shall be based on the net free area of each opening.
 - i. Where the free area through a louver or grille is known, it shall be used in calculating the opening size required to provide the free area specified.
 - ii. Where the free area through a louver or grille is not known, it shall be assumed that wooden louvers will have 25% free area and metal louvers and grilles will have 75% free area.
 - iii. Non-motorized dampers shall be fixed in the open position.
 - b. Motorized dampers shall be interlocked with the equipment so that they are proven in the full open position prior to ignition and during operation of the main burner.
 - i. The interlock shall prevent the main burner from igniting if the damper fails to open during burner startup.

- ii. The interlock shall shut down the burner if the damper closes during burner operation.

10. Combustion Air Ducts:

- a. Ducts shall be constructed of galvanized steel or an equivalent corrosion-resistant material.
- b. Ducts shall terminate in an unobstructed space, allowing free movement of combustion air to the appliances.
- c. Ducts shall serve a single space.
- d. Ducts shall not serve both upper and lower combustion air openings where both such openings are used. The separation between ducts serving upper and lower combustion air openings shall be maintained to the source of combustion air.
- e. Ducts shall not be screened where terminating in an attic space.
- f. Horizontal upper combustion air ducts shall not slope downward toward the source of the combustion air.
- g. The remaining space surrounding a chimney liner, gas vent, special gas vent, or plastic piping installed within a masonry, metal, or factory built chimney shall not be used to supply combustion air unless it is directly piped to the air inlet as shown in Figure 3.9.
- h. Combustion air intake openings located on the exterior of buildings shall have the lowest side of the combustion air intake opening at least 12 inches (305 mm) above grade.

11. Refer to Section 3 of this manual, Venting & Air Inlet Piping, for specific instructions for piping the exhaust and combustion air.

E. PLANNING THE LAYOUT

1. Prepare sketches and notes showing the layout of

the boiler installation to minimize the possibility of interferences with new or existing equipment, piping, venting and wiring.

2. The following sections of this manual should be reviewed for consideration of limitations with respect to:
 - a. Venting and Air Inlet Piping: Section 3
 - b. Water Piping: Section 4
 - c. Fuel Piping: Section 5
 - d. Condensate Removal: Section 6
 - e. Electrical Connections: Section 7
 - f. Boiler Control: Section 8
 - g. Boiler Dimensions and Ratings: Section 12

WARNING

This boiler is certified as an indoor appliance. Do not install this boiler outdoors or locate where it will be exposed to freezing temperatures.

WARNING

Do not install this boiler where gasoline or other flammable liquids or vapors are stored or are in use.

WARNING

Do not install this boiler in the attic.

2. BOILER SET-UP

A. GENERAL

1. *PureFire*® boilers are intended for installation in an area with a floor drain or in a suitable drain pan. Do not install any boiler where leaks or relief valve discharge will cause property damage.
2. The *PureFire*® boiler is not intended to support external piping. All venting and other piping should be supported independently of the boiler.
3. Install the boiler level to prevent condensate from backing up inside the boiler.

CAUTION

This boiler must be installed level to prevent condensate from backing up inside the boiler.

B. FLOOR STANDING INSTALLATION

1. For floor standing installations, use the leveling feet to assure that the boiler is completely level. This will prevent condensate from backing up in the boiler.
2. Be sure to leave adequate space for condensate piping or a pump if required.

3. VENTING & AIR INLET PIPING

A. GENERAL

1. Install the *PureFire*® boiler venting system in accordance with these instructions and with the National Fuel Gas Code, ANSI Z223.1/NFPA 54, CAN/CGA B149, and/or applicable provisions of local building codes.
2. The *PureFire*® boiler is a direct vent appliance and is ETL Listed as a Category IV appliance with Intertek Testing Laboratories, Inc.

WARNING

The venting system for this product is to be installed in strict accordance with these venting instructions. Failure to install the vent system properly may result in severe personal injury, death or major property damage.

WARNING

This vent system operates under positive pressure. Vent connectors serving appliances vented by natural draft shall not be connected into any portion of this venting system. Failure to comply may result in serious injury, death or major property damage.

3. Sources of combustion air contaminated with chlorine, ammonia or alkali agents must be avoided. Do not install this boiler near a swimming pool, hot tubs or laundry. Do not store chemicals near the boiler.

B. APPROVED MATERIALS

1. Table 3.1 lists approved materials for vent pipe (and adhesives where applicable). Use only these materials for exhaust vent piping.
2. PVC pipe and fittings are not to be used for venting in confined spaces such as closet installations. Use only CPVC or approved polypropylene (InnoFlue or PolyPro) vent pipe under these conditions.
3. Cellular core piping is approved for inlet air piping only.

WARNING

Only materials listed in Table 3.1 are approved for use with *PureFire* boilers. Use only these components in accordance with these instructions. Failure to use the correct material may result in serious injury, death, or major property damage.

WARNING

Use of cellular core pipe for any exhaust vent component is prohibited. Use of cellular core pipe may result in severe personal injury, death, or major property damage.

Table 3.1: Approved Materials for Exhaust Vent Pipe

| Description | Material | Conforming to Standard | |
|-------------------------------|---------------------|------------------------|-------------------|
| Exhaust Vent Pipe & Fittings | PVC (Sch 40 or 80)* | ANSI/ASTM D1785 | |
| | CPVC (Sch 40 or 80) | ANSI/ASTM D1785 | |
| | PVC-DWV* | ANSI/ASTM D2665 | |
| | FasNSeal® | UL1738 & ULC S636 | |
| | PolyPro® | ULC-S636 | |
| Pipe Cement (PVC & CPVC Only) | PVC/CPVC Cement | InnoFlue® | UL1738 & ULC S636 |
| | | | ANSI/ASTM D2564 |

* PVC pipe/fittings are not to be used for venting within confined spaces.

Notice: Installations in Canada require compliance with ULC S636 – Standard for Type BH Gas Venting Systems.

C. EXHAUST VENT/AIR INTAKE PIPE LOCATION

1. Install vent piping before installing water, fuel, or condensate piping. Working from largest to smallest diameter reduces the complexity of piping interferences.
2. Vent and air intake piping is to be installed so that there is sufficient access for routine inspection as required in Section 11 of this manual.
3. The vent piping for this boiler is approved for zero clearance to combustible construction. However, a fire stop must be used where the vent pipe penetrates walls or ceilings.
4. The *PureFire*® boiler, like all high efficiency, gas-fired appliances, is likely to produce a vapor plume due to condensation. Surfaces near the vent termination will likely become coated with condensation.
5. The maximum combined vent and air inlet vent length for the *PureFire* boiler is about 200 equivalent feet (60 m). Be sure that the boiler is located such that the maximum vent length is not exceeded.
6. Air Intake Pipe Location – Sidewall Venting:

NOTICE

If the maximum equivalent vent length is exceeded, the maximum burner input rate may be reduced.

- a. Provide 1 foot (30 cm) clearance from the bottom of the air intake pipe to the level of maximum snow accumulation. Snow removal may be necessary to maintain clearances.
- b. Do not locate air intake pipe in a parking area where machinery may damage the pipe.
- c. Maintain a minimum of 8" horizontal distance between exhaust vent and the air intake. Increasing this distance minimizes the potential for contamination of the inlet air with exhaust.

- d. If the vent pipe and air inlet pipe terminations penetrate the wall at the same level the minimum distance between them is 8" center-to-center.
- e. Multiple Boiler Installations:
 - The minimum horizontal distance between the inlet of one boiler to the exhaust of an adjacent boiler is 8" center-to-center. In addition, the minimum vertical distance between the exhaust air and air inlet is 6". See Figure 3.1.

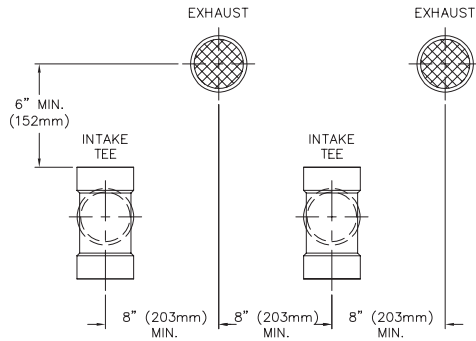

Figure 3.1: Vent Pipe Spacing for Multiple PureFire Boilers

- DO NOT CONNECT air inlet pipes together. Air inlet must be piped separately to prevent drawing exhaust and/or moist condensate back through the blower of an idle boiler.
- If multiple boilers are installed without piping the air intake to outdoors, care must be taken to be sure that the boiler room is well ventilated and is not negatively pressurized when the boilers or other air moving equipment are in operation.
- f. The exhaust outlet of the vent pipe should not be angled any more than 5° from horizontal.
- g. Precautions should be taken to prevent recirculation of flue gases to the air inlet pipe of the boiler or other adjacent appliances.

7. Sidewall Venting Configuration:

- a. See Figure 3.2 for an illustration of clearances for location of exit terminals of direct-vent venting systems.
 - The boiler vent system shall terminate a least 3 feet (0.9 m) ["B" Figure 3.2] above any forced air inlet located within 10 feet (3 m) ["A" Figure 3.2]. Note: This does not apply to the combustion air intake of a direct vent appliance.
 - Provide a minimum of 4 feet (1.22 m) distance from any door, operable window, or gravity intake into any building.
 - Provide a minimum of 1 foot (30 cm) clearance from the bottom of the exit terminal above the expected snow accumulation level. Snow removal may be required to maintain clearance.
 - Provide a minimum of 4 feet (1.22 m) horizontal clearance from electrical meters, gas meters, gas regulators, and relief equipment. In no case shall the exit terminal be above or below the aforementioned equipment unless the 4 foot horizontal distance is maintained.
 - Do not locate the exhaust exit terminal over public walkways where condensate could drip and create a hazard or nuisance.
 - When adjacent to public walkways, locate the exit terminal at least 7 feet above grade.
 - Do not locate the exhaust termination directly under roof overhangs to prevent icicles from forming or recirculation of exhaust gases from occurring.
 - Provide 3 feet clearance from the inside corner

CAUTION

Condensing flue gases can freeze on exterior building surfaces which may cause discoloration and degradation of the surfaces.

of adjacent walls.

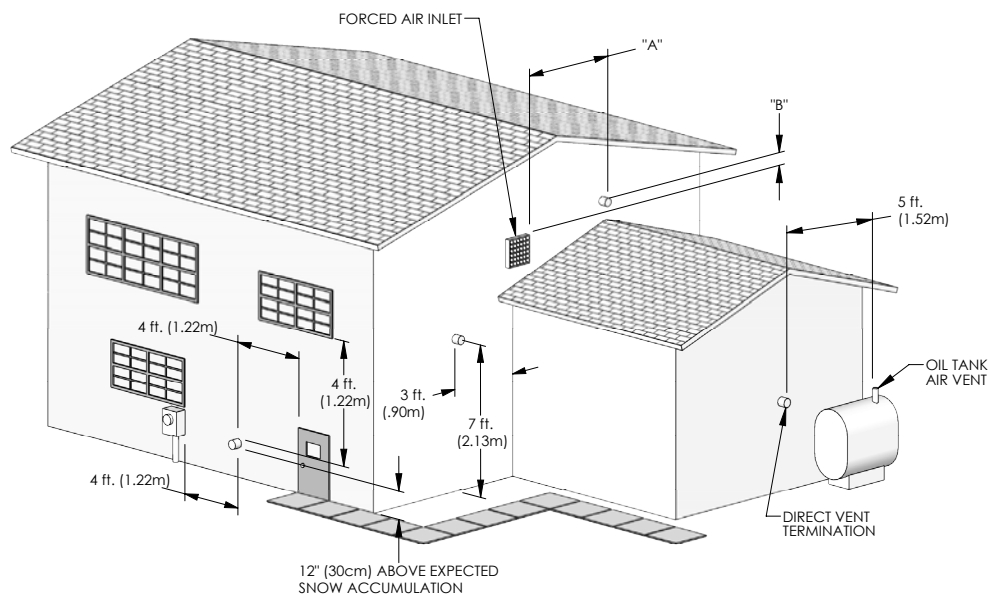

Figure 3.2: Exit Terminal Location for Mechanical Draft and Direct-Vent Venting Systems

VENTING & AIR INLET PIPING

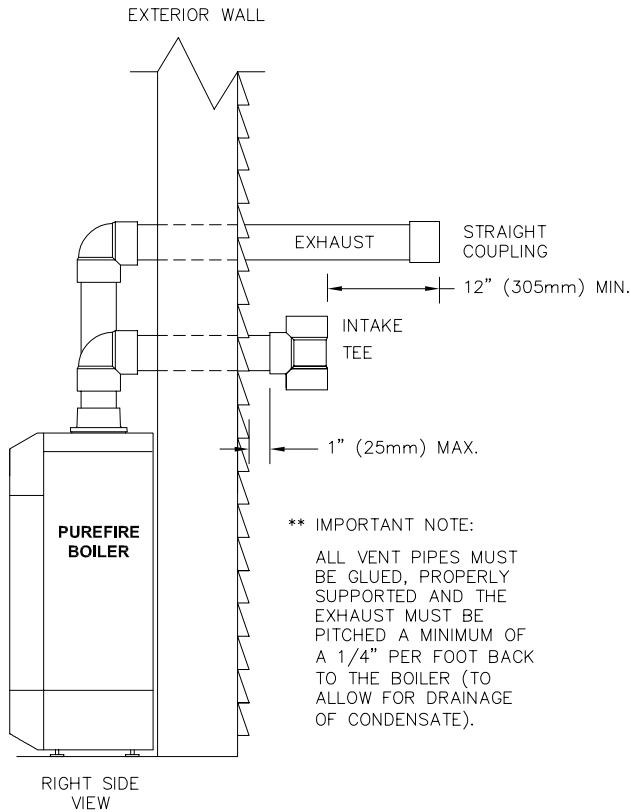

Figure 3.3: Standard Exhaust & Air Inlet Pipe Terminations

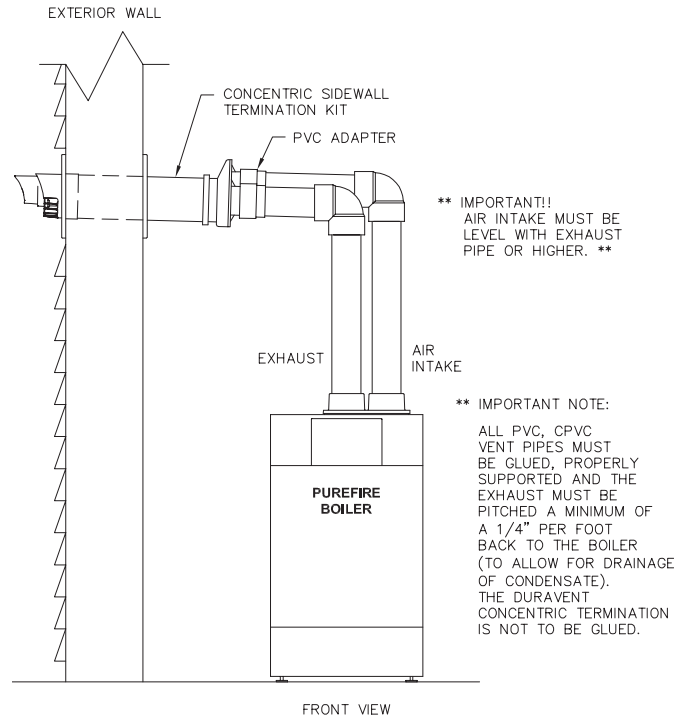

Figure 3.5: Optional Concentric Vent Kit Installation

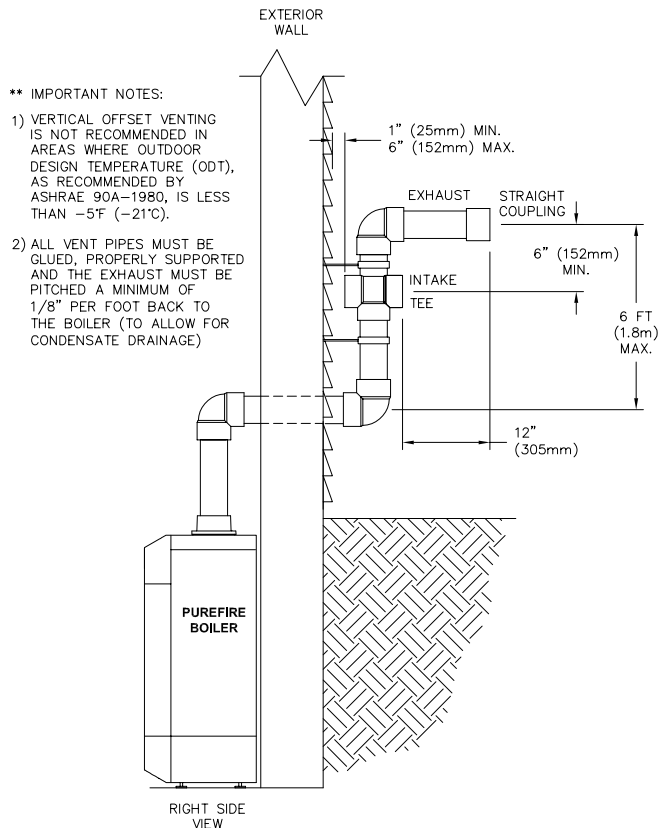

Figure 3.4: Offset Exhaust & Air Inlet Terminations

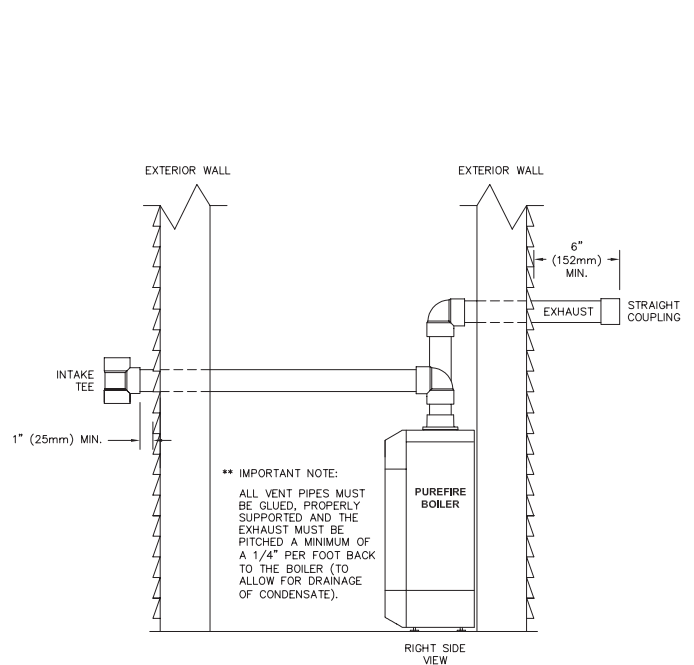

Figure 3.6: Exhaust & Air Inlet on Opposite Walls

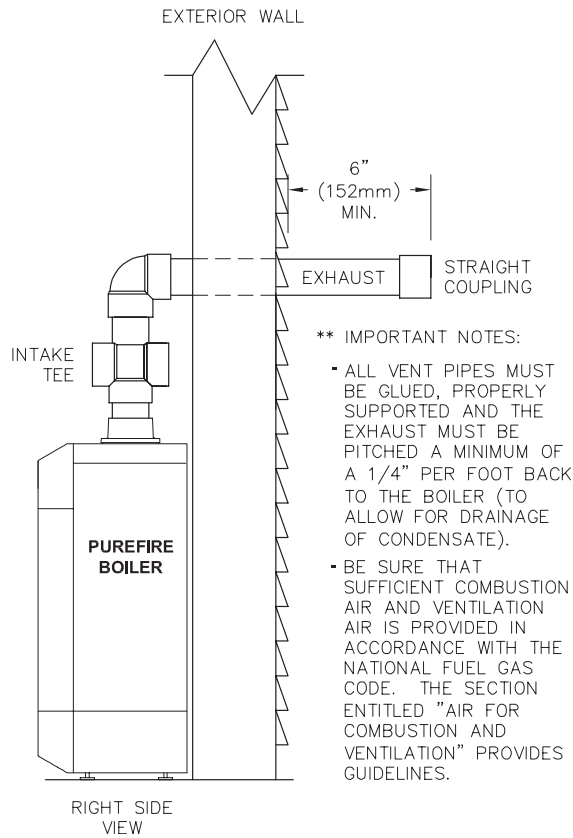

Figure 3.7: Sidewall Exhaust with Indoor Air

- Figure 3.3 and 3.4 show approved sidewall venting configurations using the standard fittings supplied.
- Figure 3.4 is only approved for locations in which the outdoor temperature is above -5°F (-21°C) in accordance with ASHRAE 90A-1980 recommendations.
- Figure 3.5 shows an approved sidewall vent configuration using an optional concentric vent termination kit. 3" (54498) or 4" (54499).
- Figure 3.6 shows an approved configuration with the exhaust termination and inlet air piped to opposite walls
- Figure 3.7 shows an approved configuration with combustion air supplied from indoors. Refer to Section 1.D to be sure that there is adequate air for combustion and ventilation at the boiler.

CAUTION

DO NOT USE the indoor air configuration shown in Figure 3.7 if there are exhaust fans or other air moving equipment (furnaces, heating boilers, etc.) in operation in the same location. Damage to equipment may occur from drawing combustion air back through and idle appliance.

- Vertical Venting Configuration:
 - Figure 3.8 shows the approved venting configuration for vertical venting using the standard fittings supplied.

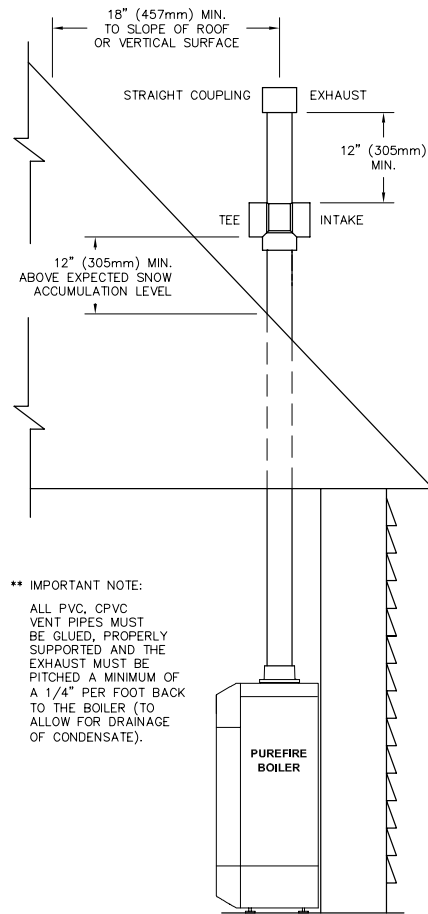

Figure 3.8: Standard Vertical Vent Installation

- Locate the air intake pipe inlet 12" above the expected snow accumulation on the roof surface or 24" above the roof surface, whichever is greater.
 - Locate the end of the exhaust vent pipe a minimum of 12" above the inlet to the air intake pipe.
- Figure 3.9 shows an approved vertical vent configuration using the optional concentric vent termination kit. 3" (54500) or 4" (54501)
 - Figure 3.10 shows an option for routing the exhaust through an unused chimney while bringing combustion air from the space surrounding the vent pipe.
 - Figure 3.11 shows an option for routing the exhaust through an unused chimney with the combustion air supplied from inside the building. Be sure to note the requirements for combustion air as listed under Section 1.D. "Combustion and Ventilation Air". These requirements are in accordance with the National Fuel Gas Code.
 - Figure 3.12 shows an option for routing the exhaust through an unused chimney in which combustion air is piped in from a sidewall.

VENTING & AIR INLET PIPING

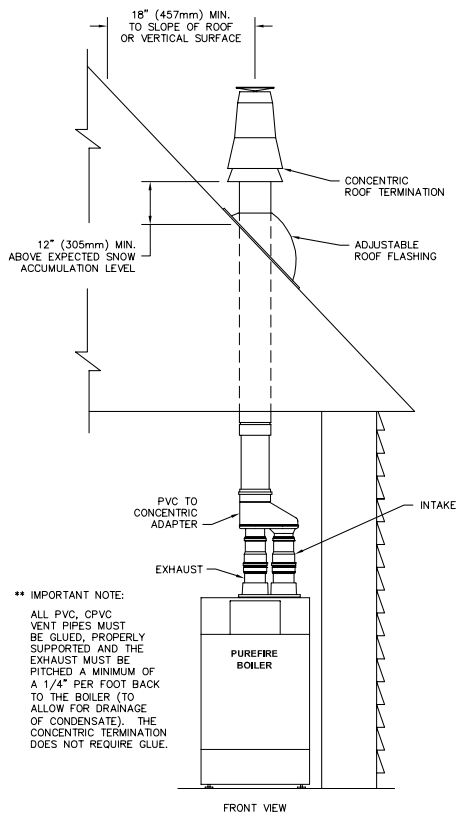

Figure 3.9: Concentric Vertical Vent Installation

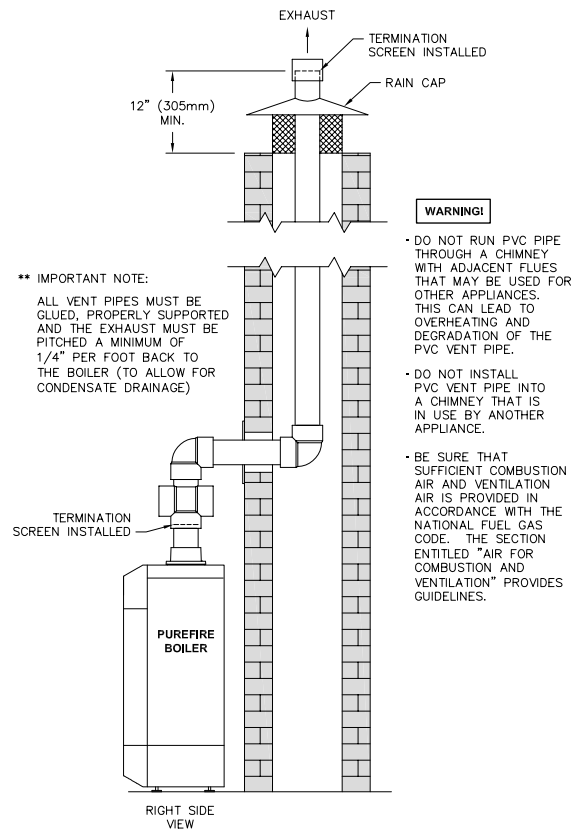

Figure 3.11: Venting Through A Chimney Using Indoor Air

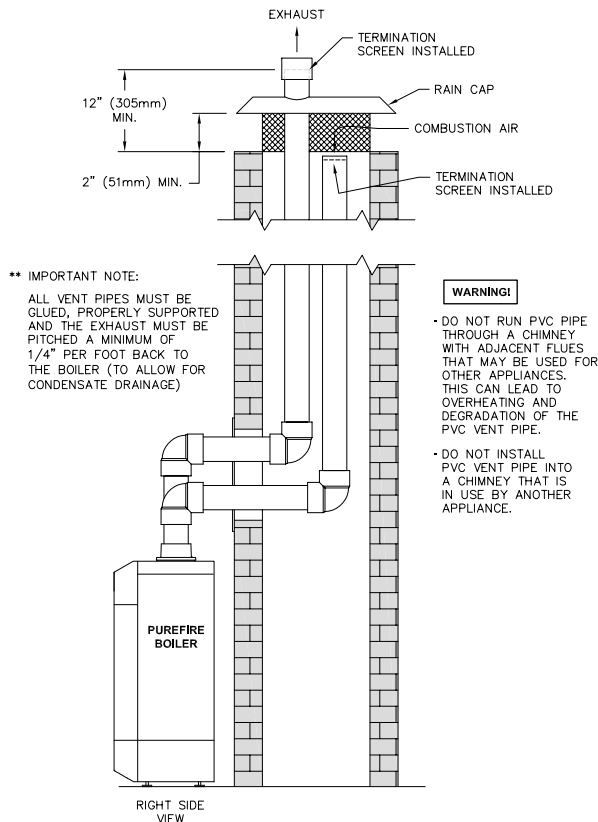

Figure 3.10: Venting Through A Chimney Using Outdoor Air

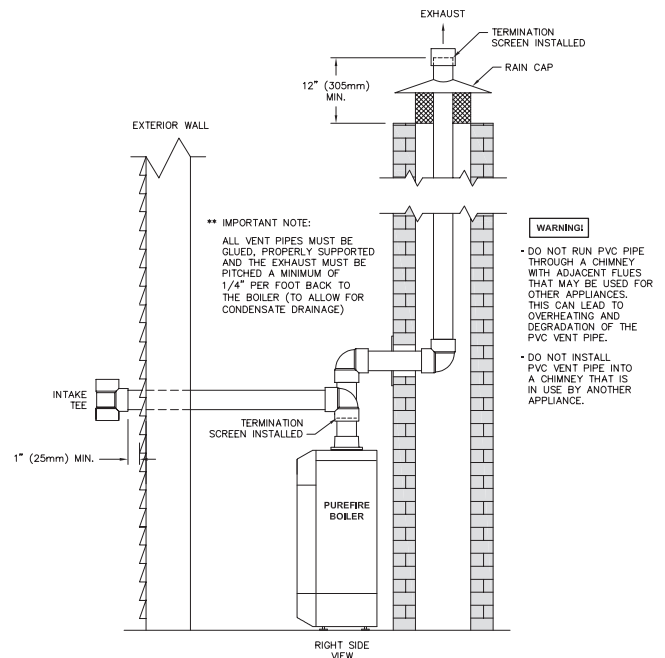

Figure 3.12: Venting Through A Chimney Using Sidewall Outside Air

D. EXHAUST VENT/AIR INTAKE PIPE SIZING

1. *PureFire*® boiler model PFW-200 is to be installed using 3" Schedule 40 or 80 PVC or CPVC piping using the provided vent adapter. *PureFire* boiler model PFW-399 is to be installed using 4" Schedule 40 or 80 PVC or CPVC using the vent adapter provided..
2. Polypropylene vent systems may be installed using optional *InnoFlue*® or *PolyPro*® vent adapters. Table 3.2 shows the appropriate PB Heat stock codes.

Contact your PB Heat Representative for more information on this option.

Table 3.2: Polypropylene Vent Adapters

| Boiler Model | Centrotherm InnoFlue® | DuraVent PolyPro® |
|--------------|-----------------------|-------------------|
| PFW-200 | 54632 | 54630 |
| PFW-399 | 54633 | 54631 |

3. Combined systems using separate polypropylene exhaust & air inlet pipes which transition to concentric can also be installed. Contact your Centrotherm or DuraVent representative for more information.
4. The total combined length of exhaust vent and air intake piping is 200 equivalent feet (60 m).
 - a. The equivalent length of elbows, tees and other fittings are listed in Table 3.3.

Table 3.3: Equivalent Length of Fittings

| Fitting Description | Equivalent Length |
|--------------------------|-------------------|
| Elbow, 90° Short Radius | 5 feet |
| Elbow, 90° Long Radius | 4 feet |
| Elbow, 45° Short Radius | 3 feet |
| Coupling | 0 feet |
| Air Intake Tee | 0 feet |
| Stainless Steel Vent Kit | 1 foot |
| Concentric Vent Kit | 3 feet |

- b. The equivalent length can be calculated as follows.

Table 3.4: Sample Equivalent Length Calculation

| | Exhaust | Air Inlet | Total |
|-------------------------|--------------|-------------|-------|
| Straight Length of Pipe | 50' | 50' | 100' |
| 90° Elbows, SR | 2 x 5' = 10' | 1 x 5' = 5' | 15' |
| 45° Elbows, SR | | 2 x 3' = 6' | 6' |
| Conc. Vent Termination | 1 x 3' = 3' | | 3' |
| | Total | | 124' |

This is well below the 200 feet maximum equivalent length. If the total is above 200 equivalent feet, alternate boiler locations or exhaust penetration location should be considered.

E. EXHAUST VENT/AIR INTAKE INSTALLATION

1. Figure 12.1 shows the exhaust connection on top of the boiler, near the rear in the center.
 - a. The exhaust connection for the PFW-200 is 3" male CPVC pipe. The exhaust connection for the PFW-399 is 4" male CPVC pipe..
 - b. These connections are to be joined with suitable PVC/CPVC adhesives in accordance with manufacturers' instructions.
2. The Air Intake connection is to the right of the exhaust.
3. Both connections are clearly marked.
4. Remove all burrs and debris from the joints and fittings.

⚠ WARNING

This appliance uses a positive pressure venting system. All joints must be sealed completely to prevent leakage of flue products into living spaces. Failure to do this may result in severe personal injury, death or major property damage.

5. Horizontal lengths of exhaust vent must be installed with a slope of not less than 1/4" per foot (21 mm per meter) toward the boiler to allow condensate to drain from the vent pipe. If the vent pipe must be piped around an obstacle that causes a low point in the piping, a drain with an appropriate trap must be installed.
6. All piping must be fully supported. Use pipe hangers at a minimum of 4 foot (1.22 meter) intervals to prevent sagging of the pipe.
7. Exhaust and air inlet piping is to be supported separately and should not apply force to the boiler.
8. Penetration openings around the vent pipe and air intake piping are to be fully sealed to prevent exhaust gases from entering building structures.
9. PVC & CPVC Piping:
 - a. Use only solid PVC or CPVC Schedule 40 or 80 pipe for exhaust venting. Cellular core PVC or CPVC is not approved for exhaust vent.
 - b. All joints in vent pipe, fittings, attachment to the boiler stub, and all vent termination joints must be properly cleaned, primed and cemented. Use only cement and primer approved for use with PVC or CPVC pipe that conforms to ANSI/ASTM D2564.
 - c. A straight coupling is provided with the boiler to be used as an outside vent termination. One of the two screens is to be installed to prevent birds or rodents from entering.
 - d. An air intake tee is provided with the boiler to be used as an outside air intake termination. A screen is to be installed to prevent birds or rodents from entering.

- e. Table 3.5 shows optional concentric air intake/exhaust terminations that are available separately from your PB Heat, LLC distributor for use with PureFire boilers

Table 3.5: Concentric Vent Termination Kits

| Boiler Model | Description | Stock Code |
|--------------|---|------------|
| PFW-200 | Sidewall Vent Termination Kit – Polypro 3PPS-HK | 54498 |
| | Vertical Vent Termination Kit – Polypro 3PPS-VK | 54500 |
| PFW-399 | Sidewall Vent Termination Kit – Polypro 3PPS-HK | 54499 |
| | Vertical Vent Termination Kit – Polypro 3PPS-VK | 54501 |

- f. Refer to Figures 3.3 to 3.6 for sidewall venting options using PVC or CPVC pipe.
- g. Refer to Figures 3.7 & 3.8 for vertical venting options using PVC or CPVC pipe.

F. EXHAUST TAPPING FOR VENT SAMPLE

To properly install the PureFire boiler, carbon dioxide (CO₂) and carbon monoxide (CO) readings must be determined from a sample of combustion products.

- To do this in PVC or CPVC vent pipe, a hole must be drilled in the exhaust vent pipe:
 - Drill a 21/64" diameter hole in the exhaust vent pipe positioned so that the combustion analyzer probe can be inserted between 6" and 12" from the boiler connection.
 - Tap the hole with a 1/8" NPT pipe tap.
 - Use a 1/8" NPT PVC or Teflon Pipe Plug to seal the hole.
- InnoFlue® and PolyPro® vent systems offer test port fittings for obtaining a sample of combustion products. See your Centrotherm or DuraVent Representative for recommendations.
- See Section 9.D.8 for instructions on taking combustion readings.

G. BOILER REMOVAL FROM COMMON VENTING SYSTEM

At the time of removal of an existing boiler, follow these steps with each appliance remaining connected to the common venting system placed in operation, while the other appliances remaining connected to the common venting system are not in operation:

Retrait de la chaudière d'un système d'évacuation commun. Au moment de retirer une chaudière existante, il est important de suivre les étapes suivantes pour chaque appareil raccordé au système d'évacuation commun qui sont en service, alors que les autres appareils demeurant raccordés au système d'évacuation commun ne sont pas en service :

- Seal any unused openings in the common venting system.

Sceller toute ouverture du système d'évacuation commun non utilisée.

- Visually inspect the venting system for proper size and horizontal pitch and determine there is no blockage or restriction, leakage, corrosion and other deficiencies which could cause an unsafe condition.

Effectuer un contrôle visuel du système d'évacuation pour vérifier la taille et la pente horizontale et s'assurer qu'il n'existe aucun blocage ou obstruction, fuite, corrosion ni tout autre problème pouvant menacer la sécurité.

- Insofar as is practical, close all building doors and windows and all doors between the space in which the appliances remaining connected to the common venting system are located and other spaces of the building.

Dans la mesure du possible, fermer toutes les portes et fenêtres de l'immeuble ainsi que toutes les portes entre l'espace dans lequel les appareils qui demeurent raccordés au système d'évacuation commun se trouvent et le reste de l'immeuble.

- Turn on any clothes dryers and any appliance not connected to common venting system. Turn on any exhaust fans, such as range hoods and bathroom exhausts, so they will operate at maximum speed. Do not operate a summer exhaust fan.

Mettre en marche les sècheuses et tout autre appareil non raccordé au système d'évacuation commun. Mettre en marche tous les ventilateurs aspirant, tels que les hottes de cuisinière et les ventilateurs de salle de bain, en les faisant fonctionner à vitesse maximum.

- Close fireplace dampers.

Ne pas faire fonctionner les ventilateurs aspirant d'été. Fermer les registres de foyers.

- Place in operation the appliance being inspected. Follow the lighting instructions. Adjust thermostat so appliance will operate continuously.

Mettre en service l'appareil à inspecter. Suivre les instructions concernant l'allumage. Régler le thermostat afin que l'appareil fonctionne sans arrêt.

- Test for spillage at the draft hood relief opening after 5 minutes of main burner operation. Use the flame of a match or candle, or smoke from a cigarette, cigar, or pipe.

Vérifier toute fuite à l'orifice de décharge du coupe-tirage après que le brûleur ait fonctionné pendant 5 minutes. Utiliser la flamme d'une allumette ou d'une chandelle ou encore la fumée d'une cigarette, d'un cigare ou d'une pipe.

4. WATER PIPING & CONTROLS

A. GENERAL

1. Size water supply and return piping in accordance with system requirements. Do not use smaller diameter piping than the boiler connections.
2. If the PureFire boiler is used to replace an existing boiler, make sure that the system piping is thoroughly cleaned and free from debris before installation.
3. In systems where sediment may exist, install a strainer in the boiler return piping to prevent large particles and pipe scale from entering the boiler heat exchanger. Use a large mesh screen in the strainer.
4. Install this boiler so that the gas ignition system components are protected from water (dripping, spraying, etc.) during operation and service (pump replacement, condensate trap cleaning, sensor replacement, etc.).
5. The PureFire® boiler is supplied with a default tank temperature setpoint of 120°F (49°C). However, the setpoint can be set as high as 158°F (70°C) which can potentially cause scald injury. If the tank temperature is set to above 120°F (49°C), PB Heat recommends the use of a mixing valve to provide lower temperature water to faucets and shower heads.

4. Table 4.2 provides the water volume of the heat exchanger including the supply and return pipes that are attached at the factory.

Table 4.2: Heat Exchanger Water Capacity

| PureFire® Model | Total Water Capacity Gallons (Liters) |
|-----------------|---------------------------------------|
| PFW-200 | 1.19 (4.50) |
| PFW-399 | 2.60 (9.84) |

NOTICE

Water temperature rise and maximum flow data is based on heating potable water with a hardness of 5 to 25 grains per gallon and total dissolved solids not exceeding 350 ppm.

5. The required temperature rise and the standard circulating pump are sized based on the heating of potable water with a hardness of 5 to 25 grains per gallon and a total dissolved solids not exceeding 350 ppm. Consult the manufacturer when heating potable water exceeding these specifications.

Heating of high hardness and/or high total dissolved solids water may require a larger circulating pump, and a revised temperature rise specification based on the water chemistry of the water to be heated.

Water with a hardness of less than 5 grains per gallon will usually have a pH which can be aggressive and corrosive causing non-warrantable damage to the pump, and associated piping. Corrosion due to water chemistry generally shows up first in the hot water system because heated water increases the rate of corrosive chemical reactions.

⚠ DANGER



Water temperatures over 125°F (52°C) can cause severe burns instantly, or death from scalds. Children, disabled, and elderly are at the highest risk of being scalded. See instruction manual before setting temperature at water heater.

Feel water before bathing or showering. Temperature limiting valves are available, see manual.

B. OPERATING PARAMETERS

1. The PureFire® boiler is designed to operate in an open loop domestic water heating system under forced circulation with a water storage tank. The system must be completely filled with water at all times and water must be circulating through the boiler while the unit is firing for it to operate effectively.
2. The minimum system pressure is 14.5 PSI (69 kPa).
3. Table 4.1 lists the minimum flow rates for each PureFire model.

Table 4.1: Minimum Flow Rate

| PureFire® Model | Minimum Water Flow Rate GPM (LPM) |
|-----------------|-----------------------------------|
| PFW-200 | 5.5 (20.8) |
| PFW-399 | 13.2 (50.0) |

C. SYSTEM COMPONENTS

1. *Pressure/Temperature Gauge:* A combination pressure/temperature gauge is provided with each boiler to be mounted in the piping from the boiler supply to the system as shown in Figure 4.1. Most local codes require this gauge.
2. *Potable Water Expansion Tank:* An expansion tank is required to provide room for expansion of the heating medium (water or glycol solution). Consult the expansion tank manufacturer's instructions for specific information regarding installation. The expansion tank is to be sized for the required system volume and capacity.
3. *Y-Type Strainer or Filter Ball® Valve:* PB Heat, LLC recommends the use of a strainer device in the system to prevent dirt or sediment from clogging the heat exchanger. A 20 mesh stainless steel screen is adequate to protect the heat exchanger. The strainer should be cleaned often in the first several months of operation. The Filter Ball® Valve from Jomar International incorporates a strainer into a ball valve which allows the technician to isolate the water circuit while cleaning the strainer.

WATER PIPING AND CONTROLS

4. **Back Flow Preventer:** A back flow preventer (check valve) is required by some jurisdictions to prevent water in the system from backing up into the city water supply.
5. **Pressure Relief Valve:** The boiler pressure relief valve is shipped separately for field installation. It is extremely important to mount this relief valve in the vertical position on the boiler supply pipe (toward the front of the boiler).

⚠ WARNING

Do not operate this appliance without installing the pressure relief valve supplied with the boiler or one with sufficient relieving capacity in accordance with the ASME Rating Plate on the boiler heat exchanger.

The valve is to be installed as shown in Figure 4.1 Pipe the discharge of the relief valve to within 12" (305 mm) of the floor and close to a floor drain.

⚠ CAUTION

Pipe the discharge of the relief valve as close as possible to the floor and away from high traffic areas. Pipe the discharge to a floor drain. Failure to do so may result in personal injury and/or property damage.

Provide piping that is the same size or larger than the relief valve outlet.

6. **Pump:** The boiler pump is to be sized to overcome the pressure drop of the system while providing the flow required by the boiler.
 - a. The pump should be sized based on gross output of the boiler. Table 4.3 shows the Boiler Output as reported to the Hydronics Institute Section of AHRI.

Table 4.3: Boiler Inputs and Outputs

| PureFire® Model | Max. Boiler Input Btu/hr (kW) | Gross Output Btu/hr (kW) |
|-----------------|-------------------------------|--------------------------|
| PFW-200 | 199,000 (58.3) | 183,000 (53.6) |
| PFW-399 | 399,000 (116.9) | 373,000 (109.3) |

- b. The required flow is calculated based on the design temperature difference from the return to the supply of the boiler. For a PFW-200 with a design temperature difference of 20°F the calculation is as follows:

$$\text{Required Flow} = \frac{\text{Output}}{\Delta T \times 500} = \frac{182,000}{20 \times 500} = 18.2 \text{ GPM}$$

- c. The boiler pressure drop for various flow rates can

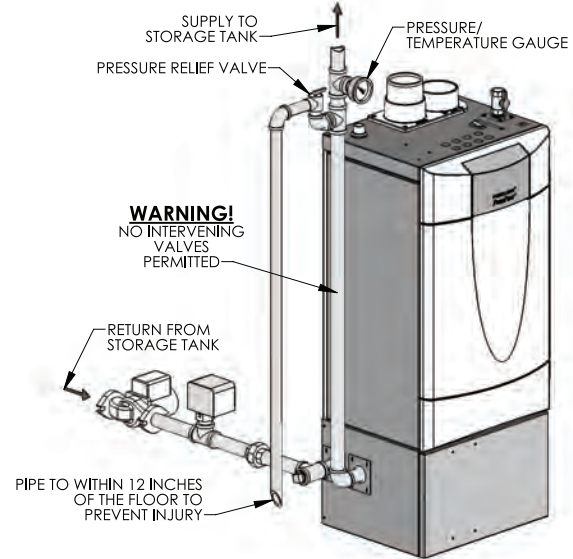

Figure 4.1: Relief Valve Installation - PFW-200 & PFW-399

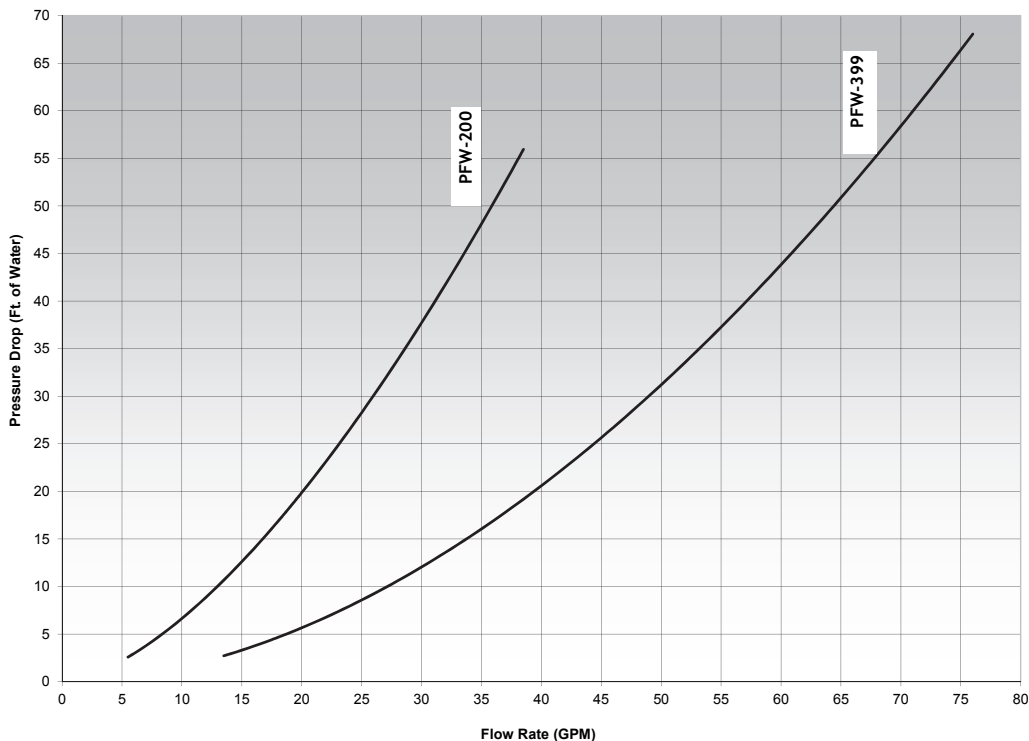

Figure 4.2: PureFire Circulator Sizing Graph

be determined using Figure 4.2, the PureFire Boiler Pump Sizing Graph.

- d. Table 4.4 provides the flow rate and pressure drop information that corresponds to 20°F temperature rise (ΔT). The pressure drop shown is for the boiler only. If there is significant system pressure drop in the circulation system between the boiler and the tank, this should be included when specifying pumps.
- e. Table 4.5 provides a list of recommended pumps for

Table 4.4: Flow Rate and Pressure Drop for Various System Temperature Rise Values

| Flow Rate vs Pressure Drop at 20°F | | | |
|------------------------------------|------------|--------------|------------|
| PFW-200 | | PFW-399 | |
| GPM (LPM) | Feet (m) | GPM (LPM) | Feet (m) |
| 18.3 (69.3) | 17.3 (5.3) | 37.3 (141.2) | 18.1 (5.5) |

PureFire® hot water supply boilers.

Table 4.5: Pump Selection Chart (20°F ΔT)

| Pump Manufacturer | PFW-200 | PFW-399 |
|-------------------|---------------------------|----------------------------|
| Bell & Gossett | PL-36 | PL-55 |
| Grundfos | UPS32-80F Medium Speed | UPS32-160F Medium Speed |
| Taco | 1400-20 | 1400-50 |

* Pumps must be bronze fitted for potable water application

- 7. *Flow Switch*: The flow switch supplied with the boiler is to be mounted as shown in figure 4.1 using the fittings supplied with a minimum straight length of 5 pipe diameters before and after the switch.

D. SYSTEM PIPING

1. Figure 4.3 shows piping for a single boiler with a single storage tank. When using the factory specified pump, the maximum total pipe length is 30 feet (10 meters) with 6 90° elbows all at the full pipe diameter of the pump connections.
2. In Figure 4.4, a single boiler is used with multiple water storage tanks. The pumps are piped in parallel with reverse return piping.
3. Figure 4.5 shows two boilers piped into a single storage tank.
4. Figure 4.6 shows piping for two boilers and two water storage tanks.
5. In Figure 4.7, we show a single boiler with a single tank using a patented anti-scale principle. In this configuration, the boiler control switches the 3-way valve to bypass when the call for heat ends. The pump is then operated to draw cool water from the anti-scale buffer tank until the supply and return temperatures equalize.
6. In Figure 4.8, a plate heat exchanger is used to isolate the boiler from the domestic hot water supply system. This strategy can be used if the domestic water does not meet the water quality guidelines presented earlier in this section. Note that a hydronic thermal expansion tank is required in this closed-loop system.

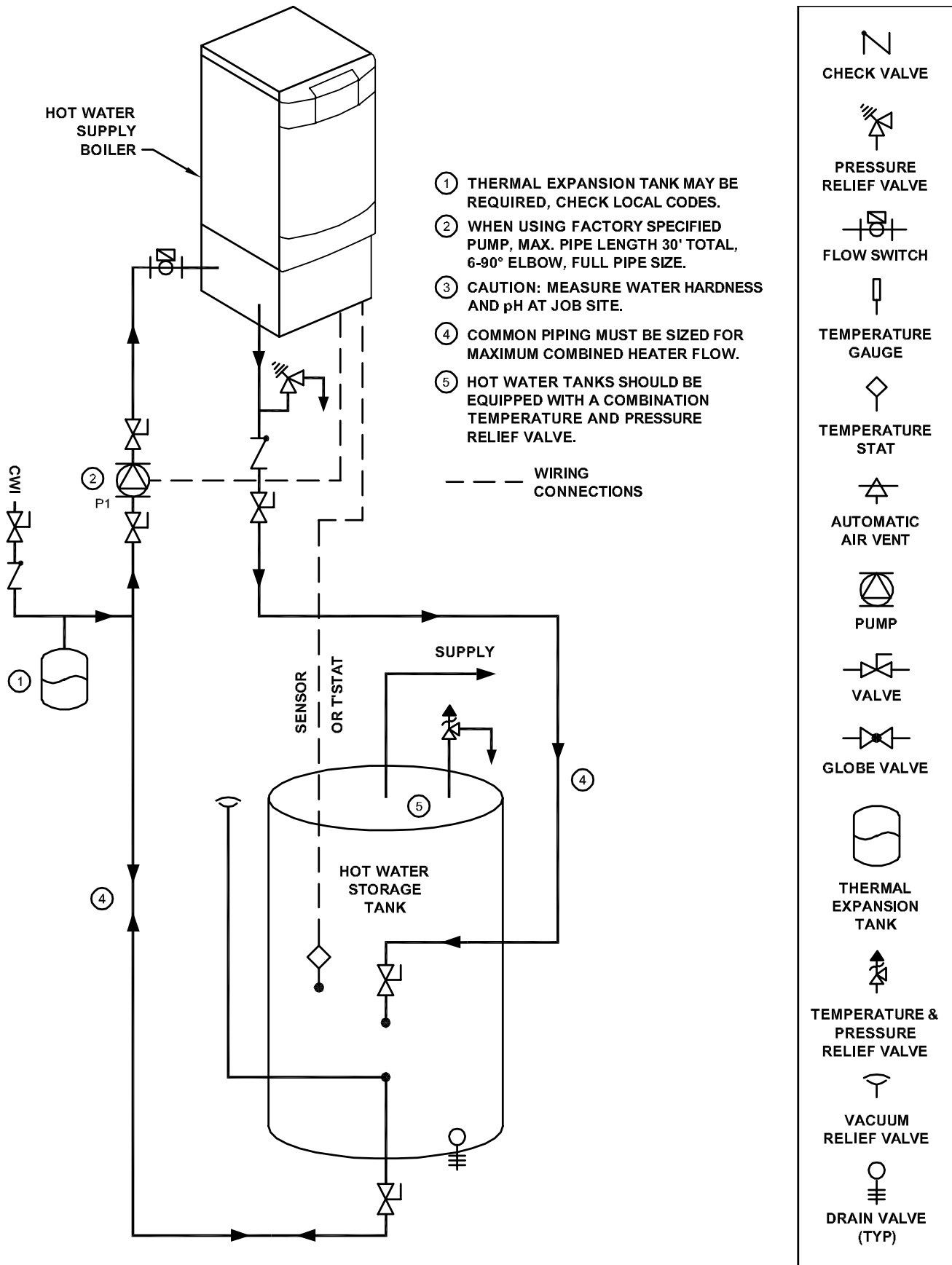

Figure 4.3: Schematic Piping - One Boiler with a Single Storage Tank

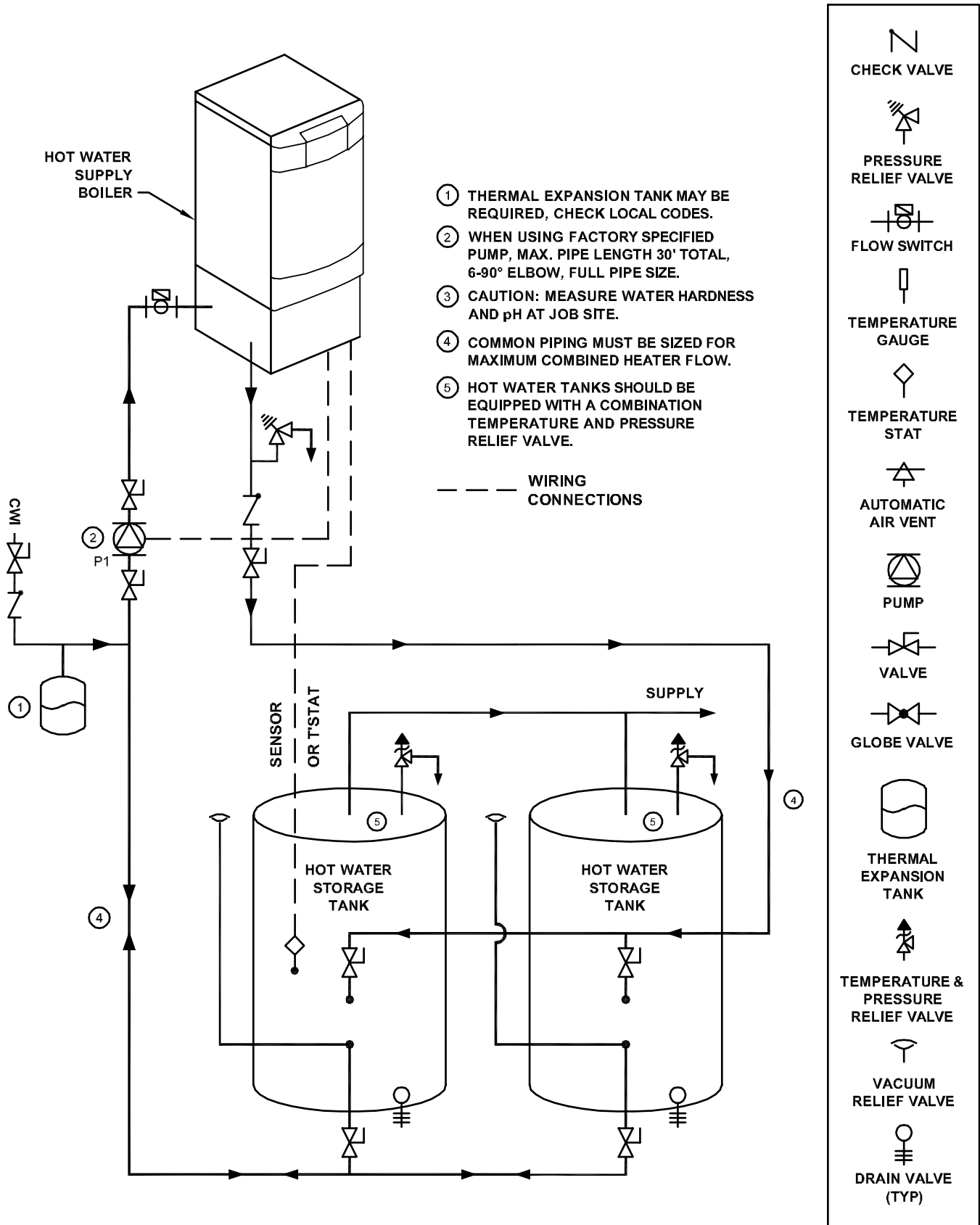

Figure 4.4: Schematic Piping - One Boiler with Multiple Storage Tanks

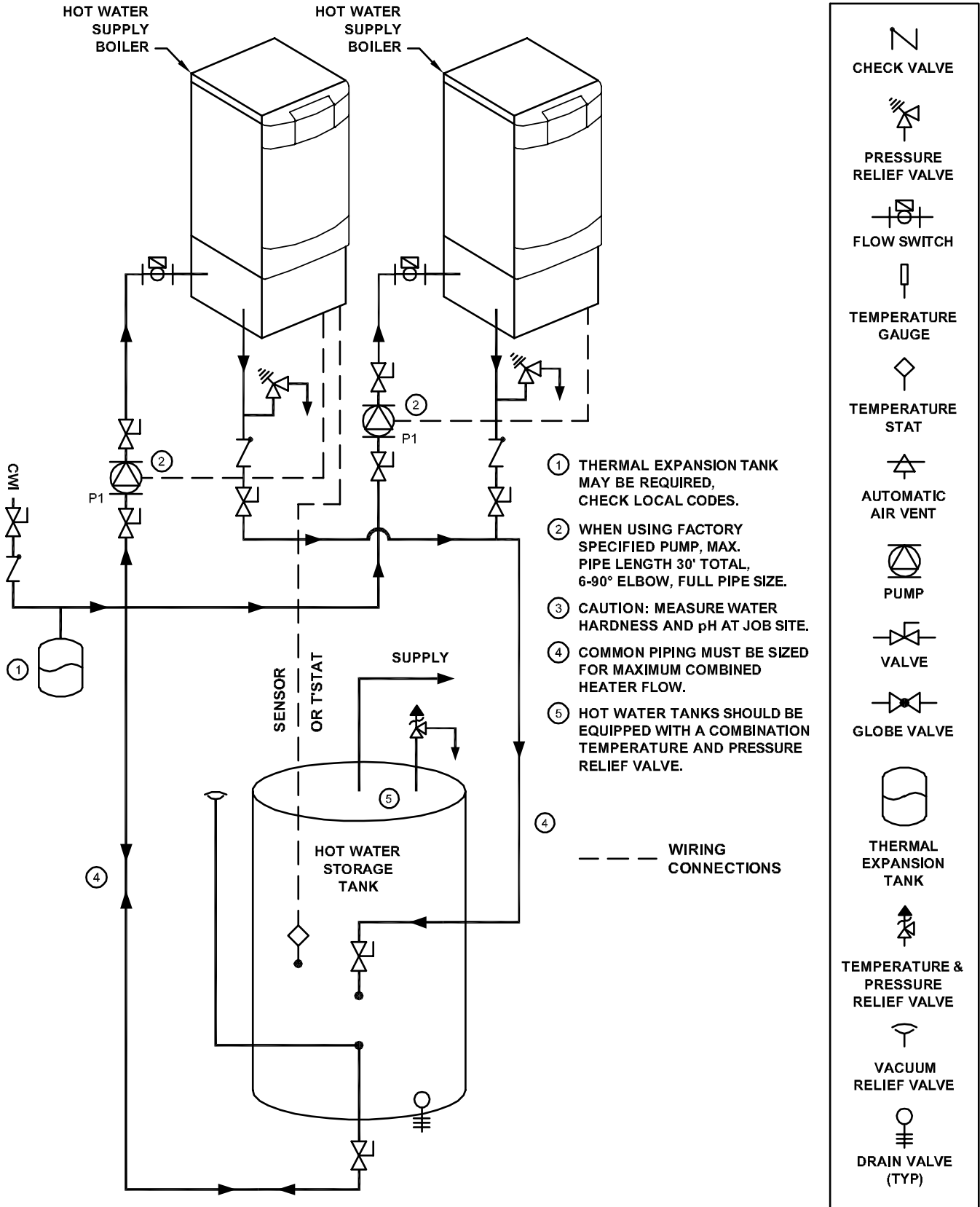

Figure 4.5: Schematic Piping - Two Boilers with a Single Storage Tank

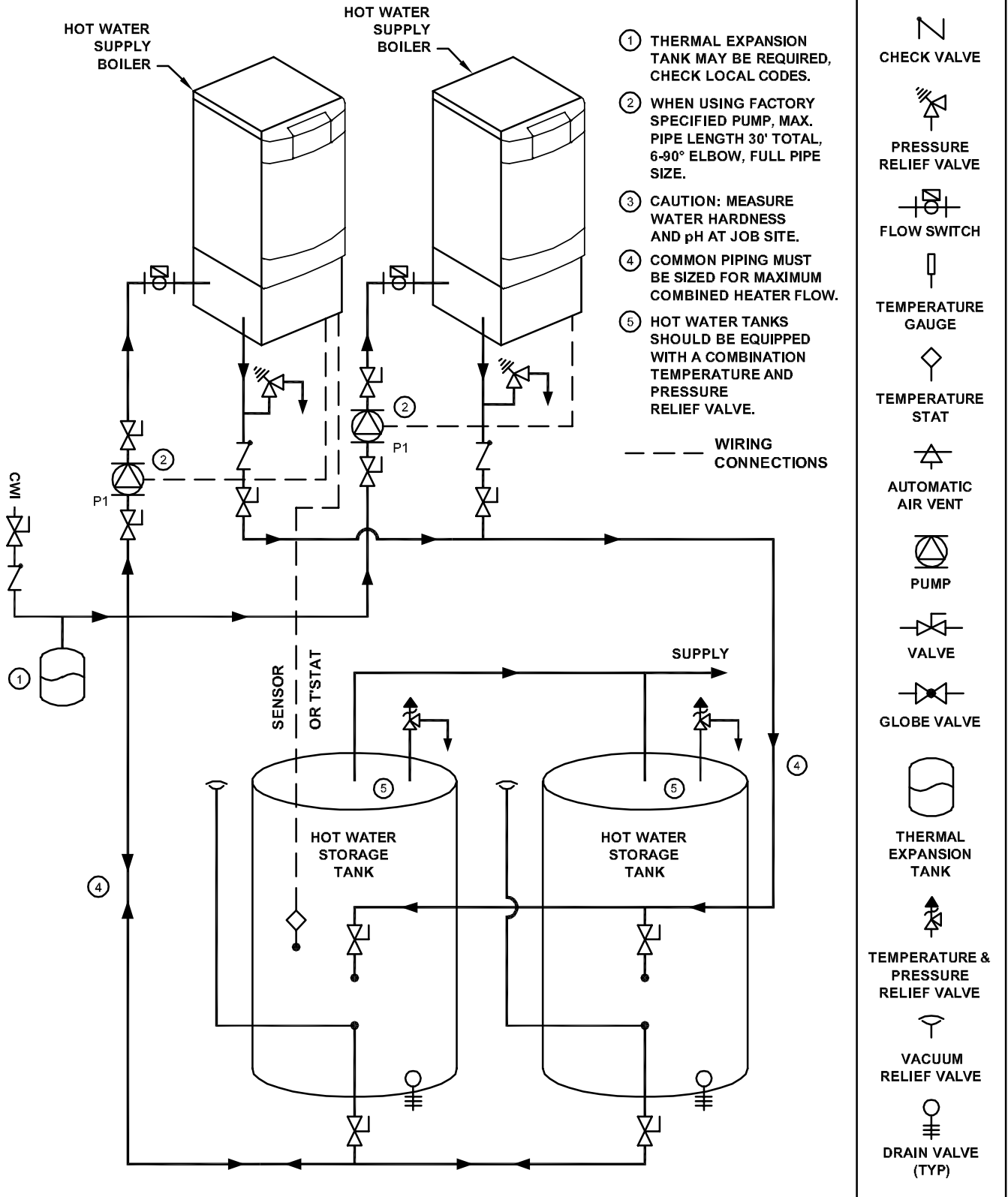
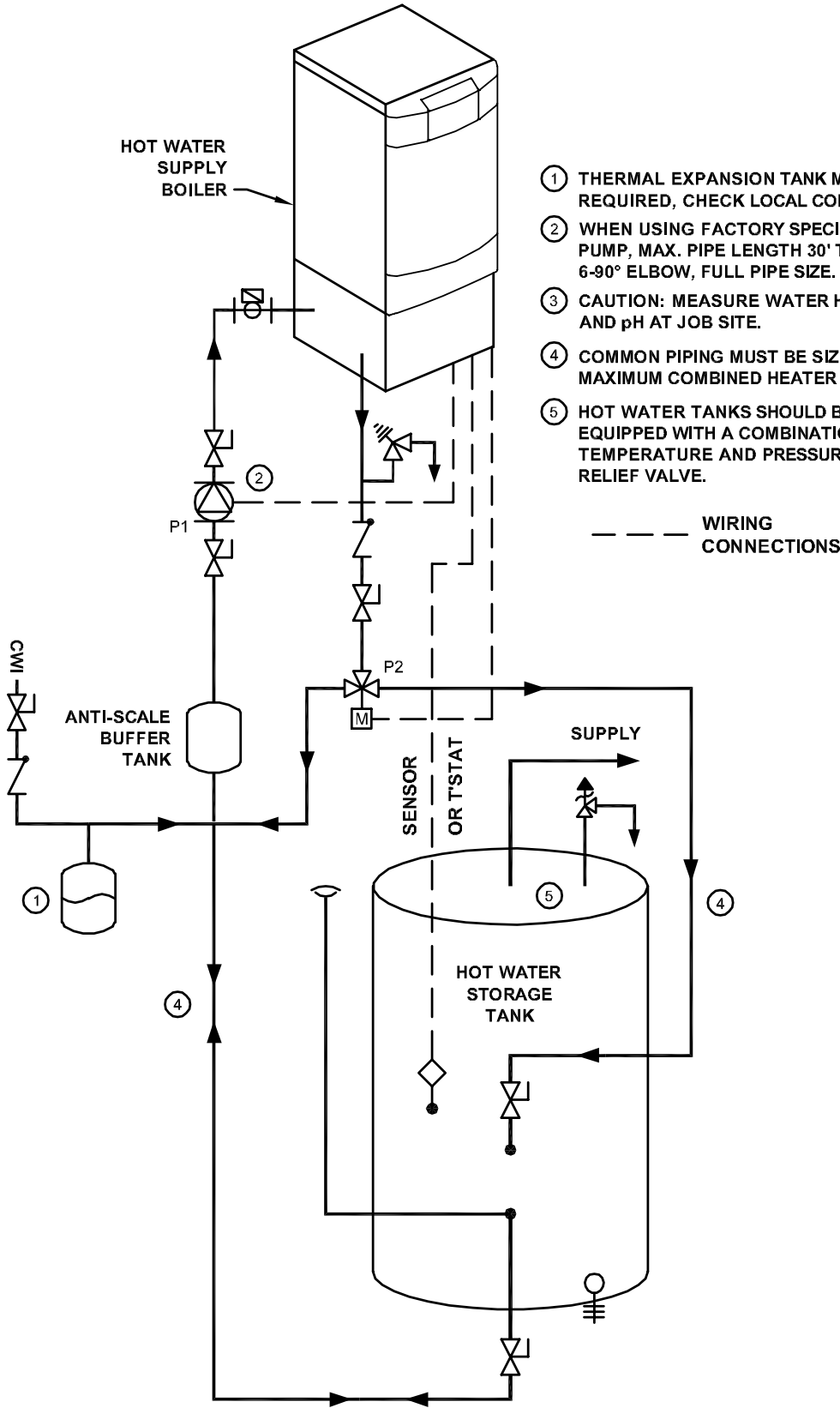

Figure 4.6: Schematic Piping - Two Boilers with Multiple Storage Tanks



- ① THERMAL EXPANSION TANK MAY BE REQUIRED, CHECK LOCAL CODES.
- ② WHEN USING FACTORY SPECIFIED PUMP, MAX. PIPE LENGTH 30' TOTAL, 6-90° ELBOW, FULL PIPE SIZE.
- ③ CAUTION: MEASURE WATER HARDNESS AND pH AT JOB SITE.
- ④ COMMON PIPING MUST BE SIZED FOR MAXIMUM COMBINED HEATER FLOW.
- ⑤ HOT WATER TANKS SHOULD BE EQUIPPED WITH A COMBINATION TEMPERATURE AND PRESSURE RELIEF VALVE.













 CHECK VALVE
 PRESSURE RELIEF VALVE
 FLOW SWITCH
 TEMPERATURE GAUGE
 TEMPERATURE STAT
 AUTOMATIC AIR VENT
 PUMP
 VALVE
 GLOBE VALVE
 THERMAL EXPANSION TANK
 TEMPERATURE & PRESSURE RELIEF VALVE
 VACUUM RELIEF VALVE
 DRAIN VALVE (TYP)

Figure 4.7: Schematic Piping - Alternate Piping with Patented Anti-Scale System

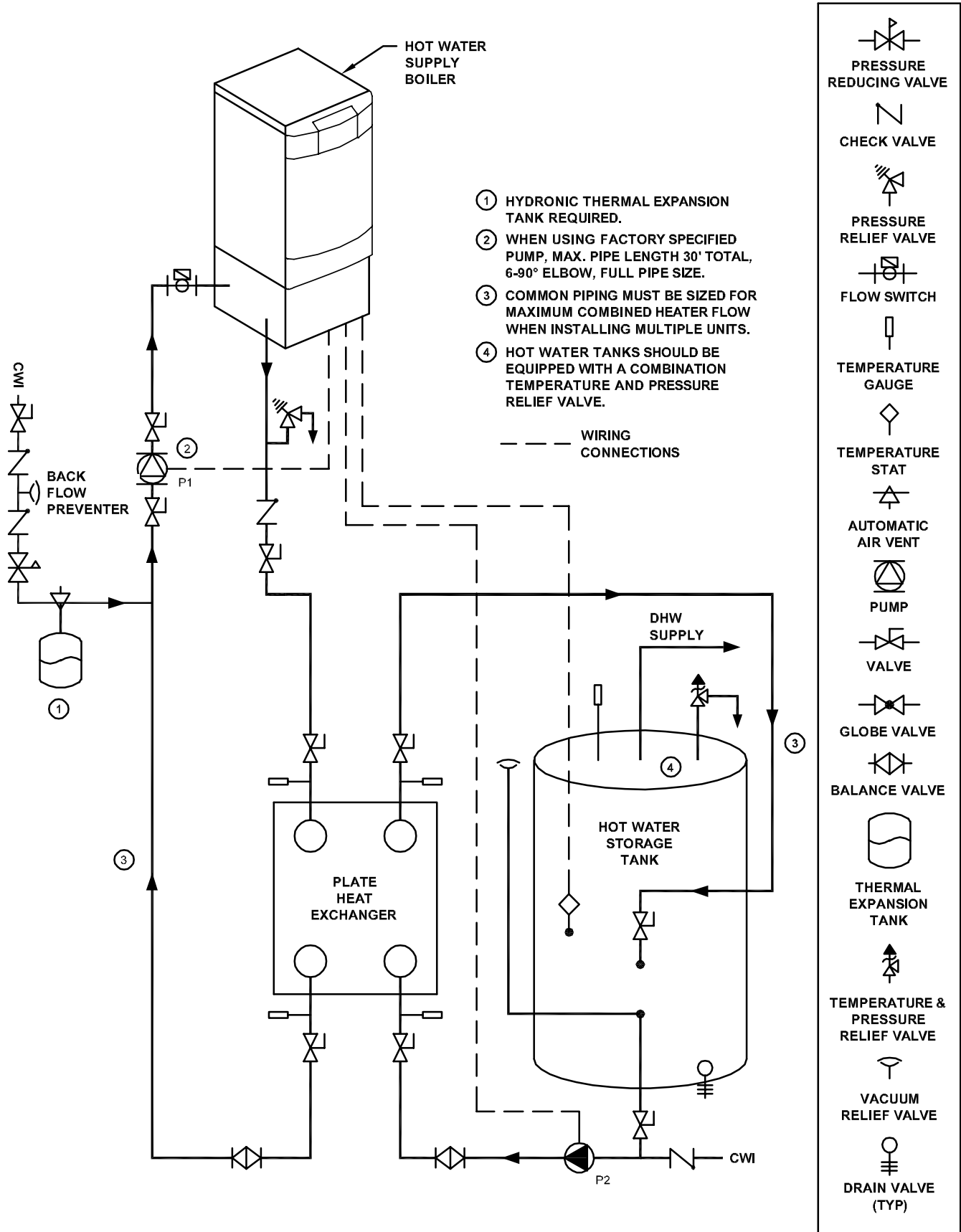

Figure 4.8: Schematic Piping - One Boiler with a Single Storage Tank & Plate Heat Exchanger

5. FUEL PIPING

A. GENERAL

1. All fuel piping to the PureFire boiler is to be in accordance with local codes. In the absence of local regulations refer to the National Fuel Gas Code, ANSI Z223.1/NFPA 54.
2. Size and install fuel piping to provide a supply of gas sufficient to meet the maximum demand of all appliances supplied by the piping.

B. FUEL LINE SIZING

1. The required flow rate of gas fuel to the boiler can be determined by the following.

$$\text{Input Rate (ft}^3\text{/hr)} = \frac{\text{Boiler Input Rate (Btu/hr)}}{\text{Gas Heating Value (Btu/ft}^3\text{)}}$$

The gas heating value can be supplied by the gas supplier.

2. As an alternative, use Table 5.1 to determine the required gas flow rate which uses typical heating values for natural gas and liquefied petroleum (LP) gas.
3. Table 5.2 shows the maximum flow capacity of several pipe sizes based on 0.3" of pressure drop.
 - a. The values shown are based on a gas specific gravity of 0.60 (Typical for natural gas).
 - b. Multiply the capacities listed by the correction factors listed for gas with a specific gravity other than 0.60 to obtain the corrected capacity.
4. Size and install the fuel gas supply piping for no more than 0.5 inches of water pressure drop between the gas regulator and the boiler.

C. GAS SUPPLY PIPING - INSTALLATION

1. Do not install any piping directly in front of the boiler or along either side. Always provide access to the front cover and side panel openings.
2. Install a sediment trap as shown in Figure 5.1. Be sure to allow clearance from the floor or other horizontal surface for removal of the pipe cap.

3. Install a ground joint union between the sediment trap and the boiler to allow service to the appliance.
4. Install a service valve as shown in Figure 5.1 to allow the gas supply to be interrupted for service.
5. Maintain a minimum distance of 10 feet (3048 mm) between the gas pressure regulator and the boiler.

Table 5.1: Required Fuel Input

| PureFire® Model | Required Input Rate* | |
|-----------------|---|--|
| | Natural Gas ft ³ /hr (m ³ /hr) | LP Gas ft ³ /hr (m ³ /hr) |
| PFW-200 | 199 (5.6) | 80 (2.3) |
| PFW-399 | 399 (11.3) | 160 (4.5) |

* Natural gas input rates are based on 1,000 Btu/ft³, LP input rates are based on 2,500 Btu/ft³.

Table 5.2: Pipe Capacity:

Maximum Capacity of pipe in cubic feet per hour (cubic meters per hour) with a pressure drop of 0.3" of water (75 Pa).

| Pipe Length ft (m) | 1/2" NPT Pipe | 3/4" NPT Pipe | 1" NPT Pipe | 1-1/4" NPT Pipe | 1-1/2" NPT Pipe |
|-----------------------|------------------|------------------|----------------|-----------------------|-----------------------|
| 10 (3.0) | 132 (3.7) | 278 (7.9) | 520 (14.7) | 1,050 (29.7) | 1,600 (45.3) |
| 20 (6.1) | 92 (2.6) | 190 (5.4) | 350 (9.9) | 730 (20.7) | 1,100 (31.1) |
| 30 (9.1) | 73 (2.1) | 152 (4.3) | 285 (8.1) | 590 (16.7) | 890 (25.2) |
| 40 (12.2) | 63 (1.8) | 130 (3.7) | 245 (6.9) | 500 (14.2) | 760 (21.5) |
| 50 (15.2) | 56 (1.6) | 115 (3.3) | 215 (6.1) | 440 (12.5) | 670 (19.0) |
| 60 (18.3) | 50 (1.4) | 105 (3.0) | 195 (5.5) | 400 (11.3) | 610 (17.3) |
| 70 (21.3) | 46 (1.3) | 96 (2.7) | 180 (5.1) | 370 (10.5) | 560 (15.9) |
| 80 (24.4) | 43 (1.2) | 90 (2.5) | 170 (4.8) | 350 (9.9) | 530 (15.0) |
| 90 (27.4) | 40 (1.1) | 84 (2.4) | 160 (4.5) | 320 (9.1) | 490 (13.9) |
| 100 (30.5) | 38 (1.1) | 79 (2.2) | 150 (4.2) | 305 (8.6) | 460 (13.0) |

The values are based on a specific gravity of 0.60 (typical for natural gas). See Table 4.3 for capacity correction factors for gases with other specific gravities.

| | | | | | | |
|-------------------|------|------|------|------|------|------|
| Specific Gravity | 0.50 | 0.55 | 0.60 | 0.65 | 0.70 | 0.75 |
| Correction Factor | 1.10 | 1.04 | 1.00 | 0.96 | 0.93 | 0.90 |
| Specific Gravity | 0.80 | 0.85 | 0.90 | 1.00 | 1.10 | 1.20 |
| Correction Factor | 0.87 | 0.84 | 0.82 | 0.78 | 0.74 | 0.71 |
| Specific Gravity | 1.30 | 1.40 | 1.50 | 1.60 | 1.70 | 1.80 |
| Correction Factor | 0.68 | 0.66 | 0.63 | 0.61 | 0.59 | 0.58 |

WARNING

Use a pipe joint sealing compound that is resistant to liquefied petroleum gas. A non-resistant compound may lose sealing ability in the presence of this gas, resulting in a gas leak. Gas leaks may potentially cause an explosion or fire.

6. Check all gas piping for leaks prior to placing the boiler in operation. Use an approved gas detector, non-corrosive leak detection fluid, or other leak detection method. If leaks are found, turn off gas flow and repair as necessary.

⚠ WARNING

When checking for leaks, do not use matches, candles, open flames or other methods that provide an ignition source. This may ignite a gas leak resulting in a fire or explosion.

7. Figure 5.1 shows the gas shutoff valve for the boiler. This valve is to be used in addition to the gas service valve shown upstream of the sediment trap.

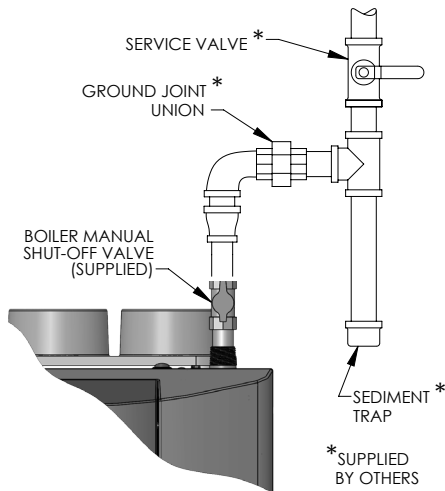

Figure 5.1: Gas Supply Pipe and Shut-off

D. GAS SUPPLY PIPING - OPERATION

1. The gas line must be properly purged of air to allow the boiler to operate properly. Failure to do so may result in burner ignition problems.
2. Table 5.3 shows the maximum and minimum fuel gas supply pressure to be measured at the gas valve inlet pressure tap. This pressure tap is depicted in Figure 5.2.
 - a. Gas pressure below 3.5 inches of water may result in burner ignition problems.
 - b. Gas pressure above 13.5 inches of water may result in damage to the automatic gas valve.

⚠ CAUTION

Do not subject the gas valve to more than 1/2 psi (13.5" W.C.) of pressure. Doing so may damage the gas valve.

Table 5.3: Maximum and Minimum Fuel Pressure

| Fuel Type | Pressure Inches W.C. (Pa) | |
|-------------|---------------------------|---------|
| | Minimum | Maximum |
| Natural Gas | 3.5 | 13.5 |
| LP Gas | 3.5 | 13.5 |

3. To check the gas supply pressure to on the gas valve:
 - a. Turn off the power at the service switch.
 - b. Close the gas shutoff valve.
 - c. Using a flat screwdriver, turn the screw inside the inlet tap fitting (see Figure 5.2) one turn counter clockwise.
 - d. Attach the tube from the manometer to the pressure tap fitting.
 - e. Open the gas valve and start the boiler.
 - f. Read and record the gas pressure while the boiler is firing.
 - g. Turn off the boiler and close the gas shutoff valve.
 - h. Remove the manometer tube from the pressure tap fitting.
 - i. Turn the internal screw clockwise to close the valve.
 - j. Turn on the gas shutoff valve and boiler service switch.
 - k. Fire the boiler and check for fuel gas odor around the gas valve. If an odor is evident check to make sure that the pressure tap fitting is closed.
4. All gas piping must be leak tested prior to placing the boiler in operation.
 - a. If the leak test pressure requirement is higher than 13.5 inches of water column, the boiler must be isolated from the gas supply piping system.
 - b. If the gas valve is exposed to pressure exceeding 13.5 inches of water column, the gas valve must be replaced.
5. Install the boiler such that the gas ignition system components are protected from water (dripping, spraying, rain, etc.) during operation and service (pump replacement, condensate collector and neutralizer cleanout, control replacement etc.)

E. MAIN GAS VALVE - OPERATION

1. Figure 5.2 is an illustration of the gas valve/venturi assembly for the PureFire boiler.
 - a. Adjustments should not be made to the gas valve without instrumentation to measure carbon dioxide (CO₂) and carbon monoxide (CO) emissions in the vent pipe.
 - b. Turning the throttle screw clockwise will decrease

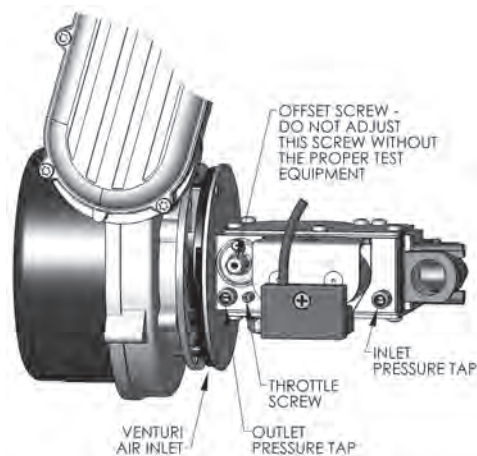

Figure 5.2: Gas Valve/Venturi

the gas flow (decreasing CO₂) and turning it counterclockwise will increase the gas flow rate (increasing CO₂). Markings adjacent to the throttle screw show + and – indicating this operation.

- c. The recommended CO₂ settings are given in Table 5.4. In no case should the boiler be allowed to operate with CO emissions above 150 ppm.

- 2. Refer to Section 3, Venting and Air Intake for information on obtaining vent samples from this boiler.

Table 5.4: Recommended Combustion Settings

| | Natural Gas | | LP Gas | |
|--|----------------|----------------|----------------|----------------|
| | Low Fire | High Fire | Low Fire | High Fire |
| Carbon Dioxide (CO₂) | 8.8% to 10.0% | 8.5% to 9.5% | 9.8% to 11.0% | 9.5% to 10.5% |
| Carbon Monoxide (CO) | < 50 ppm | < 100 ppm | < 50 ppm | < 100 ppm |
| Excess Oxygen (O₂) | 3.4% to 5.4% | 4.2% to 6.0% | 4.2% to 6.0% | 4.9% to 6.5% |
| Excess Air | 17.3% to 31.0% | 22.4% to 35.8% | 22.4% to 35.8% | 27.3% to 40.1% |

6. CONDENSATE DRAIN PIPING

A. GENERAL

1. The disposal of all condensate into public sewage systems is to be in accordance with local codes and regulations. In the absence of such codes, follow these instructions.
2. Proper piping and removal of condensation from combustion is critical to the operation of a condensing appliance. Follow these instructions carefully to assure that your boiler operates correctly.
3. Depending on several factors, the condensate from gas fired condensing appliances may have a pH value as low as 2.5 (similar to cola soft drinks). Some local codes require the use of neutralization equipment to treat acidic condensate.

B. CONDENSATE SYSTEM

The *PureFire*® condensate system is designed to prevent condensate from backing up into the heat exchanger, trap the condensate to prevent combustion gases from escaping and neutralize acidic condensate. Refer to Figure 6.1 for an illustration of the system components.

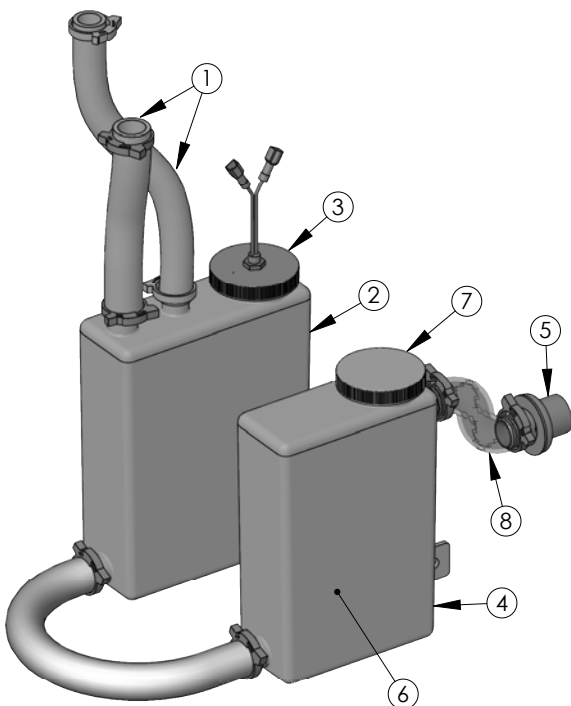

Figure 6.1: Condensate Trap System

1. *Condensate Drain Hoses*: The PFW-200 and PFW 399 have a drain hose attached directly to the combustion chamber and one connected to a bulkhead connection on top of the boiler. In systems with long exhaust vent runs, the exhaust vent should be connected to the condensate system as shown in figure 6.2. This connection will drain to the boiler's condensate trap and neutralization system.

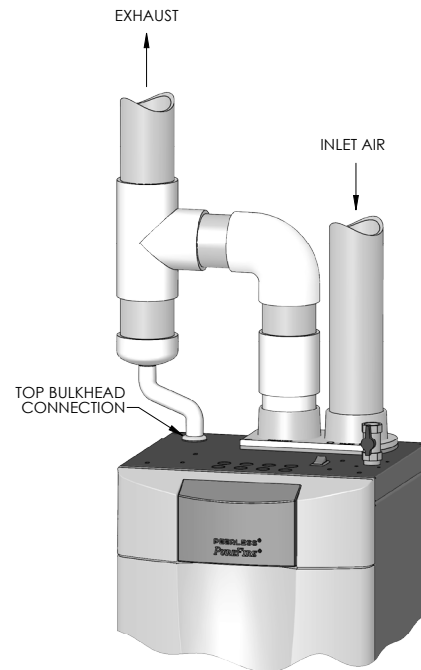

Figure 6.2: Separate Vent Condensate Drain Installation

2. *Condensate Collector Container*: The condensate collector is the semi-transparent container in the base of the boiler near the back. This container collects the condensate and acts as part of the trap to prevent combustion gases from escaping. The container is fitted with a float switch that prevents the boiler from operating if the condensate line is clogged.
3. *Condensate Float Switch*: This switch will prevent the boiler from operating if the condensate outlet is clogged before the level of condensate reaches the heat exchanger.

CONDENSATE DRAIN PIPING

4. *Condensate Neutralizer Container:* The condensate neutralizer is an additional semi-transparent container near the front of the boiler. Fill this container with the condensate neutralizer provided. The neutralizer will be consumed during normal operation and should be checked periodically to determine if the addition of neutralizer is required. Neutralizer is available in 1 lb bags (#54159) from your PB Heat Distributor.
5. *Bulkhead fitting:* The bulkhead fitting allows the condensate tubing to pass through the jacket without providing a path for leakage from the jacket. A PVC TEE is to be attached to the outlet of this fitting to prevent siphoning of the trap.
6. *Neutralizer:* Condensate neutralizer is provided in a package with the boiler to fill the condensate neutralizer container (Item 4).
7. *Neutralizer Cap:* This cap provides access for adding and inspecting the condensate neutralizer.
8. *Condensate Drain Tube:* This pre-formed tube connects the condensate system to the bulkhead fitting for attachment to an external drain.

C. CONDENSATE DRAIN PIPE MATERIAL

The condensate drain is to be piped using PVC, polypropylene, or other material resistant to acidic condensate. Do not use steel, brass or galvanized pipe for this purpose. The acidic condensate will attack most metals and corrode.

D. CONDENSATE DRAIN PIPE SIZING

The bulkhead fitting for condensate connection is for 3/4" schedule 40 PVC Pipe. Be sure to use 3/4" or larger tubing from the boiler to the drain.

E. CONDENSATE DRAIN PIPE INSTALLATION

1. Connect a 3/4" schedule 40 PVC Tee to the outlet of the bulkhead fitting as shown in Figure 6.3. Pipe from the bottom of the tee to a suitable drain.

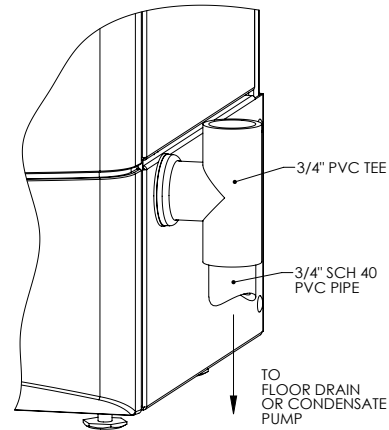

Figure 6.3: Condensate Drain Piping

2. Be sure that the piping slopes away from the boiler with a pitch of 1/4" per foot of pipe.
3. If the boiler condensate drain is above the level of a gravity drain, a condensate pump should be used. Table 6.1 lists several available brands. Contact your PB Heat Distributor for availability.

Table 6.1: Recommended Condensate Pumps

| Brand Name | Model Number |
|--------------|--------------|
| Little Giant | VCMA-15UL |
| Beckett | CB151LSUL |
| Hartell | KT-15-1UL |

7. ELECTRICAL CONNECTIONS

A. GENERAL

This appliance is to be wired in accordance with local codes and regulations as defined by the Authority having jurisdiction. In absence of such local codes, the PureFire boiler is to be wired in accordance with the latest edition of the National Electrical Code, ANSI/NFPA 70.

B. CUSTOMER CONNECTIONS

1. Electrical knockouts are provided on the top panel of the boiler to connect supply wiring, pump wiring and wiring to various instruments.
2. Electrical terminals are located behind the User Interface and can be accessed by loosening the two nuts shown in Figure 7.1.

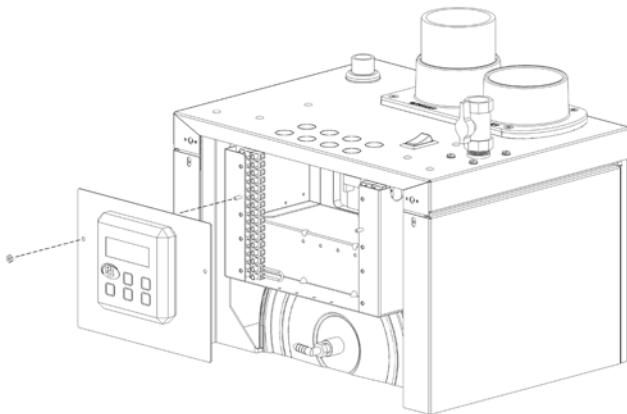

Figure 7.1: Electrical Terminal Access

- a. Remove one of the nuts and leave the other fully loosened in order to leave the display interface panel connected to the appliance.
 - b. The terminals can be removed by gently pulling them away from their wired blocks. This allows the installer to easily attach wires to the connector before plugging it into the block.
3. Figure 7.2 shows customer wiring connections for the PFW-200 and PFW-399 boilers.
 - a. Terminals 1 & 2 on the left side of the control cabinet are for low voltage connection to a switch that enables boiler operation. This is to be switched off to prevent boiler operation during service.
 - b. Terminals 5 & 6 on the left side of the control cabinet are for connection to either a DHW Tank Sensor provided (54157) or to a tank thermostat depending on the operating mode of the system.
 - c. Terminals 9 & 10 are to be connected to the flow switch provided and/or low voltage contacts of a low water cutoff device (supplied by others).

⚠ CAUTION

DO NOT Apply line voltage power to terminals 9 & 10. If a jumper is included in the low water cutoff device to supply power to the contacts, it must be removed before powering the boiler. Failure to do so may cause damage to the boiler.

- d. Terminals 11 & 12 on the left side are for connecting multiple boilers together using a cascade link which is described in Section 8.
- e. Terminals 17 & 18 on the right side are provided for either a pump or 3-way valve if used. This operation is described in Section 8.
- f. Terminals 21 & 22 on the right are for connection to the boiler circulating pump. A boiler circulator is always to be connected to assure circulation during burner operation.

⚠ CAUTION

The maximum pump/3-way valve load is 10 amps. If the load on terminals 17 & 18 or terminals 21 & 22 is greater than 10 amps, install isolation relays.

- g. Terminals 23 & 24 on the right are for the incoming 120 volt power supply.
 - h. Terminals 25 & 26 on the right provide power for a probe-type low water cutoff device. Be sure to remove any jumper that connect the 120 vac power to the device contacts so line voltage isn't applied to the low voltage terminals (9 & 10).
 - i. Terminals 27 through 30 all connect to the ground bus for any line voltage ground connections.
 - j. Terminal 31 & 32 are connect dry alarm contact connections for use with an alarm or phone dialer. These terminals are active only if the optional PFA-1 adapter is used.
4. Note that the service switch does not disconnect power to the convenience outlet.

C. INTERNAL WIRING

Figure 7.3 shows the complete boiler wiring schematic for the PureFire boiler. The following is a list of internal wiring components.

1. *User Interface:* The user interface is attached to the front of the electrical junction box and is accessible by removing the tinted lens on the front of the boiler. This interface allows users and installers to communicate with the control.
2. *Supply/Return Sensors:* These thermistors located on the left header provide supply (boiler outlet) and return (boiler inlet) temperature information to the control. Be sure to only use a 12 k Ω thermistor for this boiler.

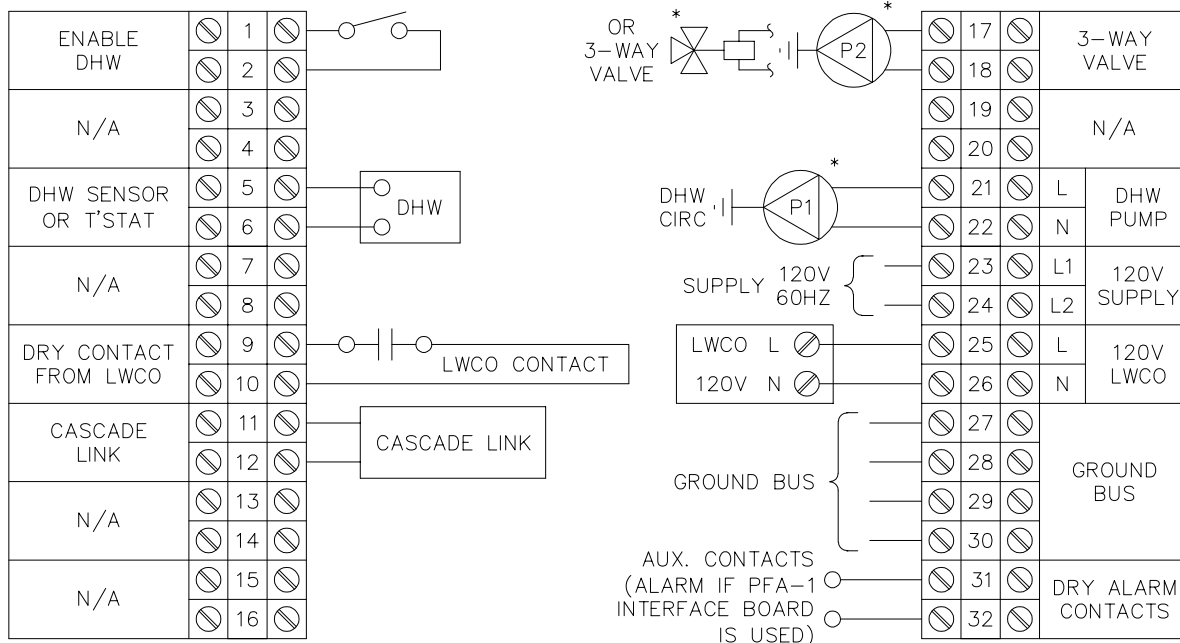

* IF PUMP OR 3-WAY VALVE LOAD EXCEEDS 10.0 AMPS USE AN ISOLATION RELAY.

Figure 7.2: Customer Connections for PFW-200 & PFW-399 Boilers

- Limit Switch:** This component is located on the left header and is differentiated from the sensors by a red Molex® connector. This is a high temperature limit switch that, when used in combination with the Argus integrated primary control, is listed in accordance with the UL353 standard for Limit Controls. It will prevent the boiler from operating if the supply water temperature reaches a temperature above 195°F (91°C). Once tripped, the boiler requires a manual reset at the boiler display interface. Be sure to only use the PureFire limit switch for this boiler.
- Flue Sensor:** This thermistor provides flue temperature information to the control. It is located in the vent connection inside the appliance jacket.
- Condensate Drain Float Switch:** This switch is mounted in the condensate collector below the heat exchanger in the rear of the cabinet.
- Service Switch:** The service switch interrupts the power to the controls to allow service to be performed. It does not disconnect incoming power and/or power to the convenience outlet.
- Convenience Outlet:** The convenience outlet is provided for a condensate pump during operation. It is not switched with the service switch to allow its use during maintenance.
- Flame Sensor:** The flame sensor uses the principal of flame rectification to sense the burner flame. This is located on the right side of the heat exchanger front plate. After ignition, the control also senses flame through the ignition electrode.
- Gas Valve:** The gas valve is connected through a special cord and connector. The connector is attached to the valve with a screw.
- Ignition Electrode:** This electrode is located on the left side of the heat exchanger front plate. A 10,000 volt charge is initiated by the control to provide a spark for lighting the burner. After the burner lights, and no spark is present, the control uses this electrode as a second source of flame detection.
- Combustion Air Fan:** The combustion air fan has two connections. There is a 120 volt power connection (3-wire) and a low voltage control connection (4-wire).
- Relay Module:** A relay module is provided that isolates the pump terminals on the integrated primary control. Current loads higher than the allowable 10 amps will require additional isolation relays.

⚠ WARNING

The service switch does not disconnect power from the convenience outlet.

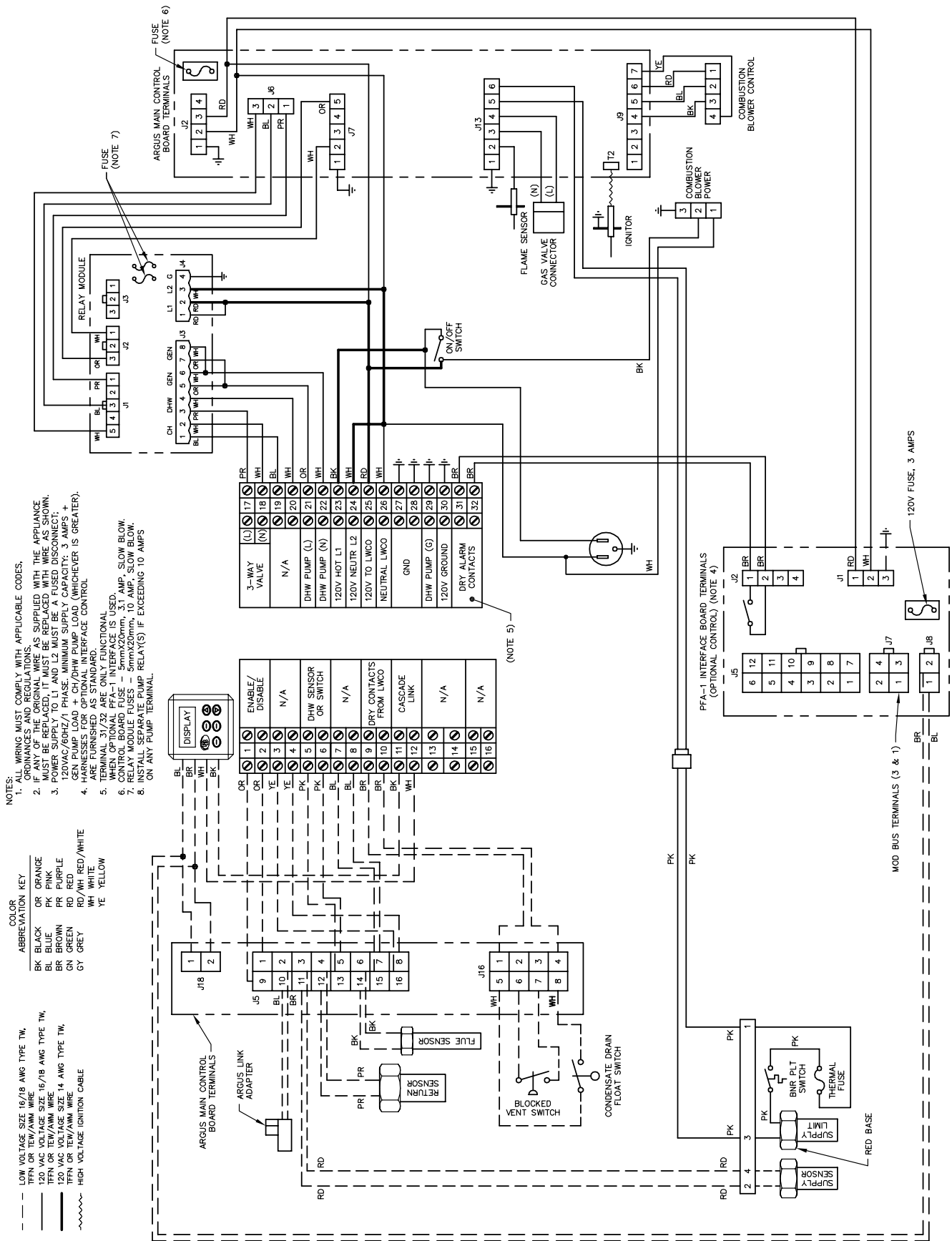

Figure 7.3: Internal Wiring Schematic for PFW-200 & PFW-399 Boilers

8. BOILER CONTROL: INTERNAL WIRING & OPERATION

A. IGNITION SEQUENCE

Figure 8.1 shows the ignition sequence for the PureFire boiler control. Table 8.1 describes each step in the sequence in detail. The boiler control provides dual sensing of the

flame to maximize the reliability. The control senses the burner flame with both the flame sensor and the ignition electrode.

Ignition Cycle

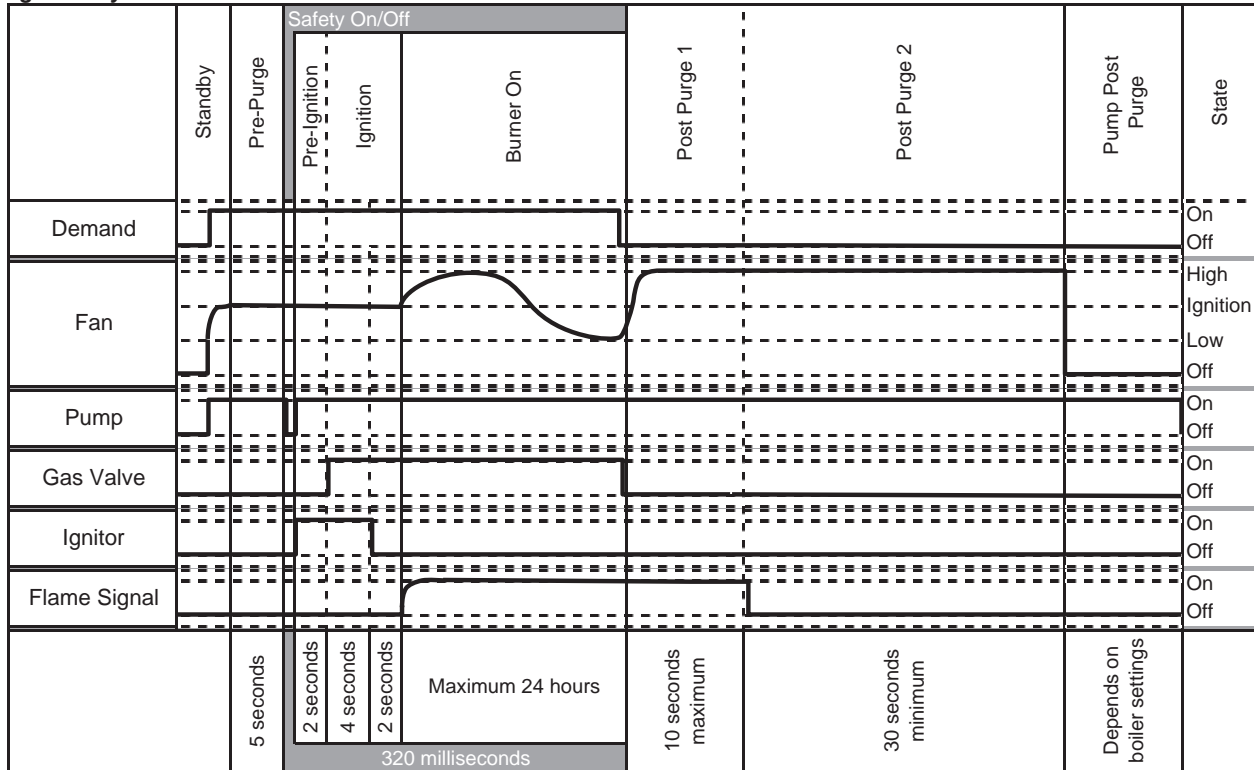









Figure 8.1: Ignition Cycle – Graphical Representation

Table 8.1: Ignition Sequence

| Period | Demand Status | User Interface Display |
|-----------|--|---|
| Standby | No demand is present. | <div style="text-align: right;">1 6 : 3 6</div> <div style="text-align: center;">S T A N D B Y</div> <div style="text-align: right;">1 6 0 ° F</div> |
| | If the power is on to the boiler and there is no DHW demand, the user interface will display “Standby” and show the boiler supply temperature in the lower right corner of the screen. The time, in 24 hour format, is shown in the upper right. When a demand is present, the boiler begins the ignition cycle. | |
| Pre Purge | A DHW demand must be present to initiate ignition. Once initiated the boiler will light. | <div style="text-align: right;">1 6 : 3 6</div> <div style="text-align: center;">D O M E S T I C H O T W A T E R</div> <div style="text-align: center;">T r i a l F o r I g n i t i o n</div> |
| | When a demand is present, the control starts the combustion air fan. The fan speed then increases to ignition speed and the user interface displays “DOMESTIC HOT WATER” along with “Trial for ignition.” This screen is displayed until the burner is lit and stable or until a fault occurs. Once the ignition sequence begins it will continue through ignition even if the demand has ended. | |

Table 8.1: Ignition Sequence (continued)

| Period | Demand Status | User Interface Display |
|---------------|--|--|
| Safety On/Off | A DHW demand has no influence in the Safety On/Off period. The Safety On/Off step will continue even if the demand has ended. |  |
| | This step very quickly opens and closes the gas valve relays and determines if the control is operating correctly. | |
| Pre-Ignition | A demand has no influence in the Pre-Ignition period. |  |
| | Once the internal check is complete, the control begins a Pre-Ignition sequence. The igniter is energized while the gas valve remains off. If a flame is detected at the end of the pre-ignition period a lockout will occur. | |
| Ignition | A demand has no influence in the Ignition period. |  |
| | |  |
| | The igniter remains energized for the first 4 seconds of the Ignition period. For the final 2 seconds of the Ignition period, the igniter is turned off and the control checks for a flame signal through both the ignition electrode and the flame sensor. If no flame signal is present at the end of the Ignition period, the control initiates a post-purge and then begins the ignition cycle again. If there are three consecutive ignition failures, the control will post purge and lockout. | |
| Burner On | A demand must be present for the control to stay in this period. |  |
| | Once the flame signal is established, the burner will run until the demand is satisfied, the setpoint is exceeded, or a blocking error occurs. The maximum run period for the burner is 24 hours. If the boiler runs continuously for 24 hours, the control will override the demand and turn off the burner. After this a restart will occur and the burner will continue to run. | |
| Post Purge 1 | After the Post Purge period begins, a demand will be ignored until after this period. |  |
| | During post purge 1, the control monitors the flame signal to be sure that the flame has extinguished. If a flame is detected after the maximum 10 second time period, a control lockout will occur. | |
| Post Purge 2 | During this period a demand has no effect on operation. |  |
| | During this period, the combustion air fan runs at high speed to purge combustion gases from the heat exchanger. The minimum setting for the fan post purge is 30 seconds. This can be increased to 90 seconds at the installer level of access. | |
| Pump Purge | No demand is present. |  |
| | The operation of the pumps and the boiler depend on the heat demand status. | |

B. USER MENU

To access the User Menu, simply press the **Menu** key on the display interface. Figure 8.2 shows the menu that will appear:

```

M E N U
→ S t a t u s
  S e t t i n g s
  M e s s a g e s
    
```

Figure 8.2: User Menu

Use the **U** and **R** keys to move the arrow pointer to the desired menu option. Then press **Select** to choose it.

1. USER MENU – STATUS

- a. **Current Setpoint:**
If the water tank is equipped with the tank temperature sensor supplied with the unit, choosing “Status” will display the tank temperature. If an independent thermostat is used, the boiler supply temperature will be displayed. These screens are shown in Figure 8.3 and 8.4:

```

S T A T U S
Current Tank
Setpoint      1 2 0 ° F ▼
    
```

Figure 8.3: Setpoint Status Display – Tank

```

S T A T U S
Current Supply
Setpoint      1 6 0 ° F ▼
    
```

Figure 8.4: Setpoint Status Display – Supply

- b. **Sensor Temperatures:**
Pressing the **U** key advances to the next status screen which shows the Supply, Return and Tank temperature sensor readings (Figure 8.5). If there is no tank sensor, the reading for DHW will show “CALL” or “NO CALL”. Pressing the **U** key again shows the System and Exhaust Vent temperature readings (Figure 8.6).

```

S T A T U S
Supply      1 6 0 ° F
Return     1 3 0 ° F
DHW       1 2 0 ° F ▼
    
```

Figure 8.5: Sensor Temperature Display #1

```

S T A T U S
System     1 6 0 ° F
Vent      1 8 0 ° F ▼
    
```

Figure 8.6: Sensor Temperature Display #2

- c. **Circulator Status:**
Pressing the **U** key once more shows the status of the General Circulator Output (Terminals 21 & 22) and the DHW Circulator Output (Terminals 17 & 18). The display will indicate if the circulators are **On** or **Off**. See Figure 8.7.

```

S T A T U S
General Circ Off
DHW Circulator Off
    
```

Figure 8.7: Circulator Status

2. USER MENU – SETTINGS

- a. **DHW Tank Setpoint & Offset:**
If the water tank is equipped with the tank temperature sensor supplied with the unit, choosing “Settings” from the user menu will display the screens shown in Figure 8.8 & 8.9.

```

S E T T I N G S
DHW Supply Offset
Offset : 1 8 ° F
Boiler SP : 1 5 8 ° F ▼
    
```

Figure 8.8: DHW Supply Offset & Boiler Setpoint

```

S E T T I N G S
DHW Tank Setpoint
1 4 0 ° F ▼
    
```

Figure 8.9: DHW Tank Setpoint

The “Offset” value is added to the “Tank Setpoint” to provide a target setpoint for the boiler supply (outlet) temperature, “Boiler SP”, when the unit is firing. To change the value, press the **Select** key and the value will begin flashing. Use the **U** and **R** keys to decrease or increase the value and then press **Select** again to save the value. Table 8.2 shows the minimum, default and maximum value for each of these parameters.

Table 8.2: Tank Setpoint & Offset Ranges

| Parameter | Minimum | Default | Maximum |
|---------------|-------------|--------------|--------------|
| Tank Setpoint | 50°F (10°C) | 140°F (60°C) | 195°F (90°C) |
| Offset | 0°F (0°C) | 18°F (10°C) | 36°F (20°C) |

Note that the Boiler SP will not exceed 195°F (90°C) if the sum of the Tank Setpoint and offset are above that value and the boiler will not target the higher value.

- b. **DHW Boiler Setpoint:**
If the water tank is using an independent thermostat to control the tank temperature, the screen shown in Figure 8.10 is displayed:

```

S E T T I N G S
DHW Supply Setpoint
1 8 0 ° F ▼
    
```

Figure 8.10: DHW Supply Setpoint

These values can be changed by using the **Select**, **U** and **R** keys as described above. Table 8.3 shows the value range for this parameters.

Table 8.3: Boiler Supply Setpoint Range

| Parameter | Minimum | Default | Maximum |
|-----------------|-------------|--------------|--------------|
| Boiler Setpoint | 50°F (10°C) | 180°F (82°C) | 195°F (90°C) |

- c. **Time & Date:**
After setting the target setpoints, press the **U** key to view the current time and date.



Figure 8.11: Time & Date Settings

These values may be changed by pressing **Select**. The day of the week will begin flashing. Use the **U** and **F** keys to select the desired day of the week, then press **Select** again. Now the “Date” value will flash. Use the **U** and **F** keys to choose the date and press **Select**. Adjust the month, year, hour and minute using the same procedure. Pressing **Select** will save the values.

- d. **Temperature Units:**
Pressing the **U** key will display the Temperature Units menu. See Figure 8.12.



Figure 8.12: Temperature Units

Press **Select** to change the value and then use the **U** and **F** keys to toggle between “Fahrenheit °F” and “Celsius °C”.

3. **User Menu – Messages**

- a. **Last Lock:**
Figure 8.13 shows the screen that displays the last error requiring a manual reset of the control that occurred with the control. Locking errors are in the form of A## and are listed in Table 10.2 in the Troubleshooting Section of this manual. A value of 255 indicates that no locking errors have occurred.



Figure 8.13: Messages – Last Locking Error

- b. **Last Block:**
Figure 8.14 represents the screen that shows the last blocking error that occurred with this control. Blocking errors are in the form of E## and are listed in Table 10.1 in the Troubleshooting Section of this manual. A value of 255 indicates that no blocking errors have occurred.



Figure 8.14: Messages – Last Blocking Error

C. INSTALLER MENU

To access the Installer Menu, press the **Menu** and **Select** key on the display interface simultaneously and hold them until the INSTALLER MENU is displayed. Figure 8.15 shows the menu:

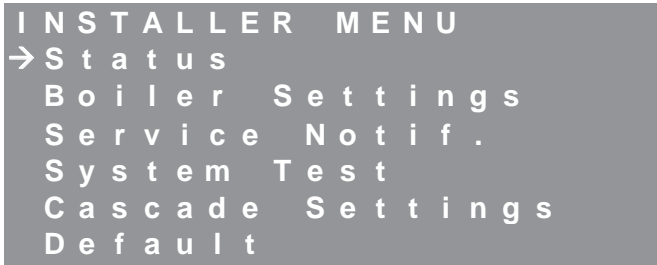

Figure 8.15: Installer Menu

Use the **U** and **F** keys to move the arrow pointer to the desired menu option. Then press **Select** to choose it.

1. **Installer Menu – Status**

- a. **Current Setpoint:**
If the water tank is equipped with the tank temperature sensor included with the boiler, the current tank setpoint is displayed on this screen (Figure 8.16). If the tank is equipped with an independent thermostat, then the current boiler supply setpoint is displayed (Figure 8.17).



Figure 8.16: Current Tank Setpoint – Tank Sensor



Figure 8.17: Current Boiler Supply Setpoint – Supply Sensor

- b. **Fan Speed:**
Press **U** key to advance to screen #2 (Figure 8.18) which shows the current fan speed in revolutions per minute (RPM). In addition, this screen displays the minimum fan speed (Low Power) for the particular model. Pressing the **U** key advances to screen #3 (Figure 8.19) which shows the ignition fan speed and the maximum fan speed (Hi Power) for the unit. The ignition speed is the fan speed that the control targets when the burner ignites.



Figure 8.18: Fan Speed (Current & Low Power)

```

STATUS 3
Fan Speed
Ignition 4650RPM
Hi Power 5940RPM
    
```

Figure 8.19: Fan Speed (Ignition & High Power)

c. Flame Signal/Failures:

Pressing the **⏏** key advances the display to screen #4 shown in Figure 8.20. This shows the current flame signal as well as the any flame failures which may have occurred since the boiler was installed.

```

STATUS 4
Flame
Signal 9.6 uA
Failures 0
    
```

Figure 8.20: Flame Signal & Flame Failures

Since the boiler control has a short lag time between receiving the flame signal and displaying it, a flame signal log records the flame signal at half second intervals during the last 2 seconds of the ignition period. Press the **⏏** key to advance through status screen #5 & #6. Screen #5 (Figure 8.21) shows the readings at 1.5 seconds (Meas. 1) and 1.0 seconds (Meas. 2) before the end of the ignition sequence. Screen #6 (Figure 8.22) displays the readings 0.5 seconds (Meas. 3) and at the end of the ignition sequence (Meas. 4). This may be helpful to determine the cause of an ignition failure.

```

BOILER SETTINGS 5 ▲
Vent Material :
PVC ▼
    
```

Figure 8.21: Flame Signal Log – Last Ignition #1 & #2

```

STATUS 6
Flame
Meas. 3 6.2 uA
Meas. 4 6.5 uA
    
```

Figure 8.22: Flame Signal Log – Last Ignition #3 & #4

d. Ignition Attempts:

Pressing the **⏏** key again advances the display to screen #7 as shown in Figure 8.23. This screen logs successful and failed ignition attempts. The total of these two numbers is the number of ignition attempts by the control.

```

STATUS 7
Ignition Attempts
Successful 1200
Failed 1
    
```

Figure 8.23: Ignition Attempts

e. Boiler Run Time:

Once again, pressing the **⏏** key advances to the next status screen. Screen #8 (Figure 8.24) displays the total run time of the control which includes the total of all time that the control is powered but not in Standby.

```

STATUS 8
Boiler Run Time
700HR
    
```

Figure 8.24: Boiler Run Time

f. Blocking Errors:

Blocking errors prevent the boiler from operating until the condition causing the error is corrected. When the error is corrected, the boiler will continue to operate. Screen #9 shows the last blocking error to occur along with the relative time of the error (Figure 8.25). The error number in the format E## corresponds to the English language description at the bottom of the screen. A complete list of Blocking Errors is provided in Table 10.1 in the Troubleshooting section of this manual.

```

STATUS #E26 9 ▲
2 Day Ago
BLOCKED CONDENSATE
DRAIN ▼
    
```

Figure 8.25: Blocking Error Status Screen

Pressing the **Select** key displays the same error, as shown in Figure 8.26, but now shows the time between this error and the previous error in its history. In this case, the “0” in the upper right corner is flashing to indicate that this was the last error to occur.

```

STATUS #E26 0
3 Hrs to prev. Block
BLOCKED CONDENSATE
DRAIN
    
```

Figure 8.26: Blocking Error – History Screen 0

Pressing the **⏏** key while the “0” is flashing will show the previous error in the control history and the number “1” will flash in the upper right. See Figure 8.27.

```

STATUS #E01 1
5 Day to prev. Block
DHW SENSOR
NOT CONNECTED
    
```

Figure 8.27: Blocking Error – History Screen 1

The **⏏** key can be used to look at all 15 of the blocking errors in the control history. When error #255 is displayed (Figure 8.28), this indicates that no errors occurred and the remainder of the errors displayed will show this message.

```

STATUS # 2 5 5 2
0 Min to prev. Block
No Messages
    
```

Figure 8.28: Blocking Error – History Screen Error #255

- g. **Locking Errors:**
Locking errors indicate a condition which requires someone to press the **Reset** key on the display to allow the boiler to resume operation. These errors are maintained in nonvolatile memory so that a power cycle will not clear the error. Screen #10 (Figure 8.29) shows the last locking error and the relative time it occurred.

```

STATUS # A 0 2 1 0 ▲
1 6 Hrs Ago
FLAME FAILURES
    
```

Figure 8.29: Locking Error Status Screen

The error number in the A## format corresponds to the English Language description at the bottom of the screen. A complete list of locking errors is provided in Table 10.2 in the Troubleshooting section of this manual. Pressing the **Select** key displays the same error but now shows the time between this error and the previous error in its history. See Figure 8.30. In this case, the “0” in the upper right corner is flashing to indicate that this was the last error to occur.

```

STATUS # A 0 2 0
3 8 Min to prev. Lock
FLAME FAILURES
    
```

Figure 8.30: Locking Error – History Screen 0

Pressing the **⏪** key while the “0” is flashing advance to the previous error in the control history and the number “1” will flash in the upper right as shown in Figure 8.31. The **⏪** key can be used to look at all 15 of the blocking errors in the control history.

```

STATUS # A 0 2 1
3 8 Min to prev. Lock
FLAME FAILURES
    
```

Figure 8.31: Locking Error – History Screen 1

When error #255 is displayed (Figure 8.32), this indicates that no errors occurred and the remainder of the errors displayed will show this message. Pressing the **Menu/Return** exits the control history screen.

```

STATUS # 2 5 5 2
0 Min to prev. Lock
No Messages
    
```

Figure 8.32: Locking Error – History Screen Error #255

2. **Installer Menu – Boiler Settings**

- a. **DHW Mode:**
Choosing “Boiler Settings” from the Installer Menu displays the DHW Mode screen depicted in Figure 8.33.

```

BOILER SETTINGS 1
DHW mode MODE: 1
DHW Store with
Sensor
    
```

Figure 8.33: DHW Mode Screen

NOTICE

In DHW Mode 1, DHW Store with Sensor, the display screen will blink continuously if the sensor is not connected to terminals #5 & #6.

The DHW mode is used to choose between several different configurations. Press the **Select** key causes the mode number to flash. Use the **⏪** and **⏩** keys to change the mode to the desired number. Press the **Select** key again to save the new value. Table 8.4 shows the available DHW Mode options:

⚠ WARNING

Be sure to use only the tank sensor provided. Other sensors may not provide accurate tank temperatures and may cause severe personal injury due to scalding.

NOTICE

The “Store Warm Hold” function will not be functional if the DHW tank mode is set to 2. This requires a DHW tank sensor.

Table 8.4: DHW Modes

| DHW Mode | Description |
|----------|--|
| 1 | Storage Tank with Temperature Sensor - Default |
| | Using the 12 kΩ thermistor supplied with the boiler, the control directly monitors the storage tank temperature and fires the boiler to maintain the desired temperature. Store Warm Hold: By monitoring the tank temperature, the control can determine if the temperature drop is due to a hot water demand or to standby losses. For standby losses, the boiler will only fire at the minimum input for maximum system efficiency. |
| 2 | Storage Tank with Separate Thermostat |
| | In this mode, the control targets a fixed boiler setpoint temperature responding to a contact closure which indicates a call for heat. |

- b. DHW Pump Post Purge:
After the storage tank is satisfied and the combustion blower post-purge stops, the control will continue to run the DHW Circulator (Terminals #21 & 22) until the difference between the supply and return temperatures on the boiler are less than TDiff from screen #3 (Figure 8.35). The time that this circulator runs is limited by the value of Max DHW Pump Postpurge Time selected on Screen #2 (Figure 8.34).



Figure 8.34: Maximum Pump Post-purge Time



Figure 8.35: Min. Supply/Return Temperature Difference

Table 8.5 shows the range and default values for both the Max DHW Postpurge Time and Min. Supply/Return Temperature Difference (TDiff).

Table 8.5: DHW Pump Purge Parameters

| Parameter | Minimum | Default | Maximum |
|-------------------------------------|---------------------------------|------------|-------------|
| Max DHW Pump Postpurge Time | 0 sec (pump postpurge disabled) | 60 seconds | 255 seconds |
| Min. Supply/Return Temp. Difference | 0°F | 4°F | 18°F |

- c. Installation Location & Vent Material:
To determine the suitable maximum vent temperature limit, the boiler control uses the Installation Location and the Vent Material. Screen #4, shown in Figure 8.36, allows selection of the Installation Location. Screen #5, shown in Figure 8.37, allows selection of the Vent Material.



Figure 8.36: Installation Location Selection



Figure 8.37: Vent Material Selection

Table 8.6 shows the vent temperature limit based on vent material and installation location (due to National Codes).

Table 8.6: Vent Temperature Limit Parameters

| Vent Material | Installation Location | |
|-----------------|-----------------------|--------------|
| | USA (Default) | Canada |
| PVC (Default) | 190°F (80°C) | 149°F (65°C) |
| CPVC | 230°F (110°C) | 190°F (80°C) |
| Polypropylene | 230°F (80°C) | 230°F (80°C) |
| Stainless Steel | 250°F (80°C) | 250°F (80°C) |

If the vent temperature approaches the vent temperature limit, the control will reduce the input rate of the boiler. If the input rate is at its minimum (1% of modulation) and the vent temperature is still at or above the limit temperature, the control will turn off the boiler. An error code of E30, High Stack Temperature, will be displayed.

The minimum signal that the control can read from the vent temperature sensor is 50°F (10°C). If the vent temperature falls below this, the boiler will monitor the boiler supply and return temperatures while it is firing. If the water supply temperature is below 120°F (49°C) and the return temperature is below 80°F (27°C) the boiler will operate normally. If either of these temperatures exceed the indicated value, the control will limit the boiler input to minimum firing rate (1% of modulation). This is done to prevent overheating of the exhaust vent material.

- d. Freeze Protection:
This feature is intended to protect from freezing temperatures in the boiler system. If the supply temperature drops below the freeze protection starting point, the DHW pump (Terminals #21 & 22) are activated. If the supply temperature drops more than 9°F (5°C) below this temperature, the control starts the burner and operates it at its minimum input rate (1% of modulation). Figure 8.38 shows the screen used to adjust the Freeze Protection temperature start. This is under the Boiler Settings screen on the Installer Menu.



Figure 8.38: Freeze Protection Starting Temperature

Table 8.7 shows the minimum, default and maximum temperature values for this parameter.

Table 8.7: Freeze Protection Value Range

| Parameter | Minimum | Default | Maximum |
|-----------------------------|------------|-------------|-------------|
| Freeze Protection start at: | 45°F (7°C) | 50°F (10°C) | 56°F (13°C) |

e. Additional Safety Functions:

- The installer can choose between a low water cut-off (LWCO) or a flow switch to prevent firing of the boiler without sufficient water in the system. Figure 8.39 shows the selection screen for Additional Safety Functions.



Figure 8.39: Additional Safety Functions Selection

- The control is shipped with LowWaterCO as a default setting and includes a factory supplied jumper that allows the boiler to operate if this safety device is not installed. Table 8.8 shows the available options for this parameter.

Table 8.8: Additional Safety Function Values

| Parameter | Default | Alternate |
|-----------------------------|------------|-------------|
| Additional Safety Functions | LowWaterCO | Flow Switch |

- If the boiler is set to flow switch, the control first checks to assure that the circuit is open before turning on the pump. Once the pump is on, the control requires the flow switch circuit to be closed.
 - The system can accept both a LWCO and flow switch as long as they are wired in series so that the circuit opens when there is no flow in the boiler.
- f. Blower Post Purge:
The installing contractor can increase the blower post-purge time from the 30 second minimum up to 120 seconds in 1 second increments. Figure 8.40 shows the Blower Post-purge Setting screen.



Figure 8.40: Blower Post-purge Setting

Table 8.9 shows the range of values for the Blower Post-purge time. Keep in mind that increasing the blower post-purge time can adversely affect the efficiency of the boiler.

Table 8.9: Blower Post Purge Time Value Range

| Parameter | Minimum | Default | Maximum |
|------------------------|------------|------------|-------------|
| Blower Post-purge Time | 30 seconds | 30 seconds | 120 seconds |

3. **Installer Menu - Service Notification**

- a. The boiler allows the service technician to set up notifications for routine maintenance. When enabled, the notification can be set up on Hours of Operation, Cycles, or on a pre-determined date. When the notification criteria are met, the screen shown in Figure 8.41 is displayed with “SERVICE” flashing.



Figure 8.41: Service Notification Status

- b. To reset the hour or cycle counters, press the Select key on Screen #1 under Service Notification shown in Figure 8.42.



Figure 8.42: Reset Notification Time or Cycles

- c. Screen #2, shown in Figure 8.43, is used to set the notification criteria. Table 8.10 shows the choices for this parameter:



Figure 8.43: Notification Criteria

Table 8.10: Notification Criteria

| Criteria | Minimum | Default | Maximum |
|----------|---------------------------------|------------|------------|
| Off | Notification Disabled (Default) | | |
| HRS | 0 HRS | 4000 HRS | 8000 HRS |
| CYCLES | 0 CYC | 20,000 CYC | 50,000 CYC |
| DATE | Set Date, Month & Year | | |

- d. To set the number of hours until notification, press the **Select** key while viewing Screen #3, shown in Figure 8.44, and press the **U** and **D** keys to change the number of hours in 100 hour increments.



Figure 8.44: Notification on Hours

- e. Similarly to set the number of cycles, press the **Select** key while viewing Screen #4 shown in Figure 8.45 and press the **t** and **s** keys to change the number of cycles in 1000 cycle increments.



Figure 8.45: Notification on Cycles

- f. Finally, to set a fixed date:
 - Press the Select key while viewing Screen #5, shown in Figure 8.46, and press the t and s keys to change the Date (0-31). Press the Select key again to advance to the Month.



Figure 8.46: Notification on Date

- Press the **U** and **F** keys to change the Month (JAN-DEC). Press the **Select** key again to advance to the Year.
 - Press the **U** and **F** keys to change the Year. Press the **Select** key again to save.
4. **Installer Menu – System Test**
 - a. To allow service technicians to run the system at a fixed input rate for commissioning and troubleshooting purposes, the boiler control is equipped with a System Test function.



Figure 8.47: System Test Menu

- b. Use the **U** and **F** keys to move the arrow pointer to the desired menu option. Then press **Select** to choose it.
- c. Choosing “Low Power” will operate the boiler at its minimum input rate. A “SYSTEM TEST” message will blink at the top of the status screen and the boiler will run at its minimum temperature unless either the temperature of the tank or boiler supply is at or above the setpoint. In this case, the control will not fire until both temperatures are below the setpoint.
- d. When the boiler first starts, the modulation rate indication display the ignition modulation rate (approximately 70%) lower left of the screen. Once the burner is lit, the input rate will drop to its minimum and 1% will be displayed to indicate minimum modulation rate. See Figure 8.48.



Figure 8.48: System Test Status Display

- e. Similarly, choosing “Maximum Power” will operate the boiler at its rated capacity. With this selected the display will show 100% after ignition is established.

5. Installer Menu – Default Settings

- a. The boiler allows a service person to reset all of the boiler settings to the default settings that were set up at the factory. To reset the default values choose “Default Values” from the Installer Menu. Figure 8.49 shows the Factory Defaults Reset screen. Simply press the **Select** key to reset the factory default values.



Figure 8.49: Restore Factory Defaults

- b. The control also allows the service technician to Save and then Restore site default settings. The screens depicted in Figure 8.50 and 8.51 show these options.



Figure 8.50: Save Site Defaults



Figure 8.51: Restore Site Defaults

6. Installer Menu – Cascade Settings (Multiple Boilers)

- a. The boiler allows system designs that include up to 8 boilers cascading operation without the use of external sequencing controls.
- b. Figure 8.52 illustrates the wiring for interconnecting cascaded boilers. No other wiring is required between the boilers.
- c. Managing Boiler Designation: To set up the cascade system, one of the boilers is to be designated the Managing boiler. This will be the boiler that controls the system and will be connected to the tank temperature sensor or tank thermostat.
 - First, switch the Master Switch Lever to the “ON” position. The Master Switch Lever is in the “ON” position when it is moved toward the center of the printed circuit board as shown in Figure 8.53.
 - Next, from the installer menu, choose Cascade Settings from the Installer Menu. Figure 8.54 shows the Address Selection screen that is used to identify boilers in the cascade system. Press the Select key and then use the **F** key to change from “0” (indicating a stand-alone boiler) to “1” (indicating the Managing Boiler).

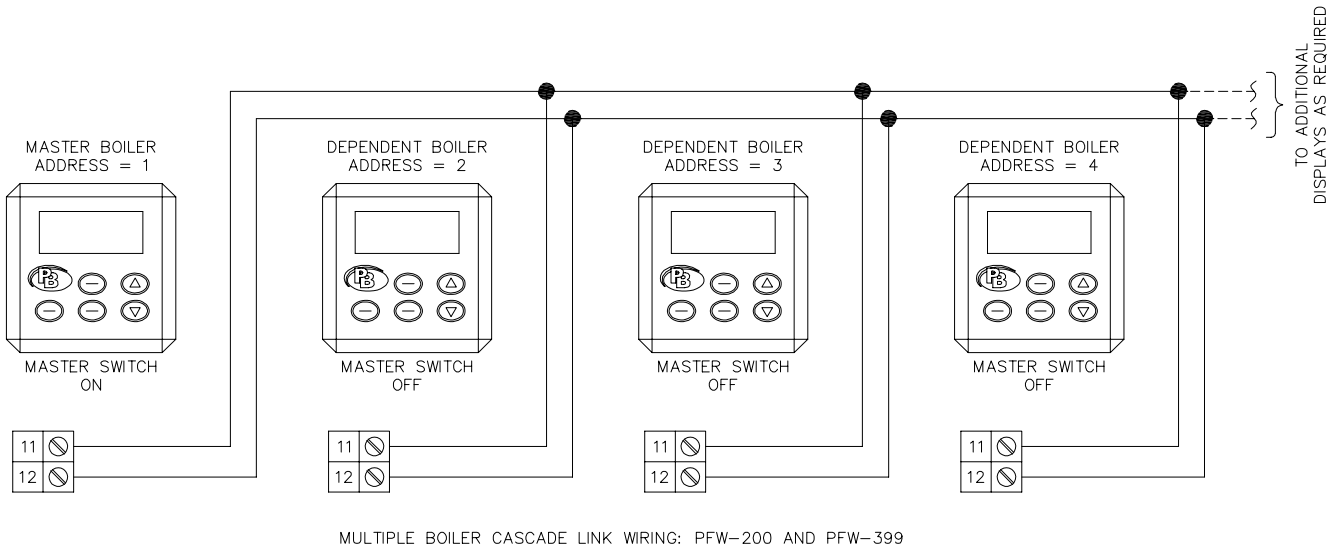

Figure 8.52: Interconnection of Cascade Link Wires

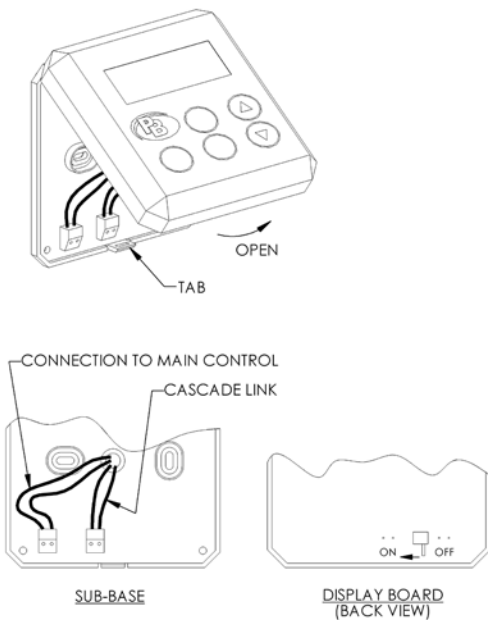

Figure 8.53: Switching the Master Switch to the "ON" position



Figure 8.54: Cascade Address Selection

- d. **Dependent Boiler Designation:** Dependent boilers must have different boiler addresses "2" to "8". Each dependent boiler must be connected to a circulating pump. Table 8.11 shows address selections for Stand-alone, Managing & Dependent boilers.

Table 8.11: Boiler Address Selection Range

| Parameter | Stand-alone (Default) | Managing Boiler | Dependent Boilers |
|----------------|-----------------------|-----------------|-------------------|
| Boiler Address | 0 | 1 | 2-8 |

- e. **Cascade Operation:** When a call for hot water is present, either from a thermostat or a by sensing low tank temperature, the master boiler chooses a lead boiler based on the Cascade Rotation Interval (See Below).
 - The control starts the lead boiler. After the start delay time, each boiler in the cascade system is started in succession.



Figure 8.55: Start Delay Time

Table 8.12: Start Delay Time Range

| Parameter | Minimum | Default | Maximum |
|------------------|------------|------------|-------------------------|
| Start Delay Time | 10 seconds | 10 seconds | 240 seconds (4 minutes) |

The default value of this parameter is the minimum to prevent a long delay before starting another boiler. If the delay is significant, it is possible that the tank temperature will fall before all boilers are in operation. If many boilers are installed and the load is highly variable, consider using two cascade systems. In this case, the tank sensors for each system can be placed such that the second group of boilers only comes on if there is a very large load.

- With all the boilers operating, the system will modulate the gas input to each of the boilers to follow the system load. The control uses the Stop Delay Time and the Stop Boiler Differential values to determine when to drop a boiler from the sequence.



Figure 8.56: Cascade Stop Delay Time



Figure 8.57: Cascade Stop Boiler Differential

Table 8.12: Start Delay Time Range

| Parameter | Minimum | Default | Maximum |
|--------------------------|----------|----------|------------|
| Stop Delay Time | 1 minute | 1 minute | 15 minutes |
| Stop Boiler Differential | 1°F | 18°F | 45°F |

If the tank temperature exceeds the Tank Setpoint + the Stop Boiler Differential for longer than the Stop Delay Time, it will stop one of the boilers.

- The control uses the Tank Setpoint + the Offset Temperature as set in the User menu to provide a Boiler Supply Setpoint. It will then offset this setpoint up or down to meet the tank temperature. The Calculated Setpoint Max Offset Up (Figure 8.58) and Calculated Setpoint Max Offset Down (Figure 8.59) are used to limit this offset. Increasing either of these parameters may cause the system to react more quickly, but may result in frequent cycling. It may be necessary to reduce the Max Offset Up to prevent a lockout on boiler limit.



Figure 8.58: Calculated Setpoint Max Offset Up



Figure 8.59: Calculated Setpoint Max Offset Down

Table 8.13 shows the range of values for these parameters.

Table 8.13: Calculated Setpoint Max Offset Up/Down

| Parameter | Minimum | Default | Maximum |
|-------------------------------------|---------|---------|---------|
| Calculated Setpoint Max Offset Up | 0°F | 18°F | 36°F |
| Calculated Setpoint Max Offset Down | 0°F | 9°F | 36°F |

- The control also uses the Next Boiler Stop Rate to determine when to shed a boiler from the cascade system. Figure 8.60 and Table 8.14 show the screen and the range of values.



Figure 8.60: Next Boiler Stop Rate

Table 8.14: Next Boiler Stop Rate

| Parameter | Minimum | Default | Maximum |
|-----------------------|---------|---------|---------|
| Next Boiler Stop Rate | 5% | 9% | 40% |

- The Cascade Rotation Interval (Figure 8.61) will change the frequency at which the control will change the lead boiler in the system.



Figure 8.61: Rotation Interval

- Table 8.15 shows how the Rotation Interval affects the boiler rotation sequence.

Table 8.15: Rotation Interval (4 Boilers)

| Days of Operation | 1 Day | 3 Days | 5 days |
|-------------------|---------|---------|---------|
| 1 | 1-2-3-4 | 1-2-3-4 | 1-2-3-4 |
| 2 | 2-3-4-1 | 1-2-3-4 | 1-2-3-4 |
| 3 | 3-4-1-2 | 1-2-3-4 | 1-2-3-4 |
| 4 | 4-1-2-3 | 2-3-4-1 | 1-2-3-4 |
| 5 | 1-2-3-4 | 2-3-4-1 | 1-2-3-4 |
| 6 | 2-3-4-1 | 2-3-4-1 | 2-3-4-1 |
| 7 | 3-4-1-2 | 3-4-1-2 | 2-3-4-1 |
| 8 | 4-1-2-3 | 3-4-1-2 | 2-3-4-1 |
| 9 | 1-2-3-4 | 3-4-1-2 | 2-3-4-1 |
| 10 | 2-3-4-1 | 4-1-2-3 | 2-3-4-1 |
| 11 | 3-4-1-2 | 4-1-2-3 | 3-4-1-2 |
| 12 | 4-1-2-3 | 4-1-2-3 | 3-4-1-2 |

9. START-UP PROCEDURE

A. GENERAL

1. Confirm that all water, gas and electricity are turned off.
2. Verify that the water piping, venting & air intake piping, gas piping, electrical wiring and electrical components are installed in accordance with the manufacturer's instructions. Be sure that the boiler is installed in accordance with this manual and good engineering practice.
3. Turn on electricity and gas to the boiler

B. CHECK WATER PIPING

1. Fill the boiler and system with water, making certain to purge all air from the system. Open each vent in the system until all air is released and water begins to be discharged. Then close the vent.
2. The pressure reducing valve on the fill line will typically allow the system to be pressurized to 12 PSI. Consult manufacturer's instructions for operation of the valve and expansion tank.
3. Check joints and fittings throughout the system and repair as required.

C. CHECK GAS PIPING

1. Turn on gas to the boiler using the shut-off valve upstream of the sediment trap. Be sure that the gas shut-off valve supplied with the boiler is in the closed position.
2. Connect a manometer to the gas supply upstream of the supplied manual gas valve.
3. Confirm that the gas supply pressure to the boiler is between the minimum and maximum values as indicated in Section 5.
4. If a supply pressure check is required, isolate the boiler and gas valve before performing the pressure test. If the supply pressure is too high or too low, contact the fuel gas supplier.
5. Double check the fuel gas supply pressure after the boiler is running to be sure that the pressure doesn't drop off significantly under operation.

D. CHECK OPERATION

1. Be sure that the circuit between terminals #1 & #2 is open to disable boiler operation.
2. Turn on electricity to the boiler leaving the manual gas valves closed. Check to see that LCD display is lit. Figure 9.1 shows the status display.

```

D H W   D i s a b l e d   1 6 : 3 6
S T A N D B Y

-----
T a n k : 1 6 0 ° F
  
```

Figure 9.1: Status Display DHW Disabled

3. Refer to Section 8, Boiler Control, to set up the control for the desired operation.
4. Close terminal #1 & #2 either with a switch or jumper to enable boiler operation. Before opening the gas valves, allow the boiler to attempt ignition 3 times before locking out on Ignition Failure (A01). Then turn the manual gas valves on and push the Reset key.
5. Use the ignition sequence, Figure 8.1 to follow the light off and shutdown sequences and to assist in troubleshooting operation problems. If the boiler does not function properly, consult Section 10, Troubleshooting.
6. After starting the boiler, be certain that all controls are working properly and that the combustion is properly set up. Paragraphs 7 and 8 below provide instructions on how check combustion.
7. Check that the boiler will shut down when the supply water temperature reaches the control setpoint.
 - a. Note the boiler setpoint by accessing the User Menu, Status Display. Press the **Menu** key on the keypad. Choose Status by pressing the **Select** key. Use the **Up** and **Down** keys to scroll through available parameters. Refer to Section 8.B for information on User Menu options.
 - b. Use the System Test Mode in the Installer Menu to choose High Input Power.
 - c. Monitor the boiler temperature on the temperature gauge (supplied for field mounting) and on the Status display.
 - d. The boiler should shut down at the boiler setpoint plus 10°F (5°C). If it does not shut down, turn off the boiler and contact your PB Heat representative.
8. Check combustion readings in the boiler vent pipe.
 - a. For PVC or CPVC exhaust vent pipe only: Drill and tap a 1/8" NPT threaded hole in the boiler vent pipe within 12" (305 mm) of the boiler vent connection. (21/64" Drill and 1/8" NPT Pipe Tap recommended) This is to be used as the combustion test port for the combustion analyzer. See Figure 9.2.
 - b. Polypropylene vent systems from Centrotherm or Duravent should include a sample port fitting connected to the exhaust outlet port of the boiler. In this case, this fitting is to be used as the test port for the combustion analyzer.
 - c. Using a combustion analyzer with the capability to read carbon dioxide (CO₂) and carbon monoxide



Figure 9.2: Drill and Tap Combustion Test Port

(CO), place the probe into the combustion test port. See Figure 9.3.

- d. Manually set the boiler to Maximum power by entering the System Test Mode. See Appendix C,



Figure 9.3: Insert Analyzer Test Probe into Test Port

Installer Menu.

- Verify that the fan speed indicated is within 30 rpm of the maximum power fan speed in Table 12.2.
 - Verify that the CO and CO₂ emissions are within the parameters specified in Table 5.4.
- e. Manually set the boiler to Low Power by entering

the System Test Mode. See Appendix C, Installer Menu.

- Verify that the fan speed indicated is within 100 rpm of the Low Power fan speed listed in Table 12.2.
 - Verify that the CO and CO₂ emissions are within the parameters specified in Table 5.4.
- f. If the values in either of these instances falls outside the parameters listed in Table 5.4, turn off the boiler and contact your PB Heat representative. For best results, the value should be set for the middle of the range (9% for Natural Gas and 10% for LP Gas).
 - g. Be sure to set the System Test mode to Off so that the boiler will modulate correctly in accordance with the load.
 - h. After removing the analysis probe from the vent pipe, insert a PVC or Stainless Steel pipe plug into the test port. See Figure 9.4.
 - i. Record the combustion readings on the “Start-



Figure 9.4: Insert Pipe Plug into Test Port

up Combustion Record” in Appendix D. It is very important to record all of the information requested on the sheet for follow up and troubleshooting.

E. LIGHTING & OPERATING PROCEDURES

FOR YOUR SAFETY READ BEFORE OPERATING

WARNING: If you do not follow these instructions exactly, a fire or explosion may result causing property damage, personal injury, or loss of life.

A. This appliance does not have a pilot. It is equipped with an ignition device which automatically lights the burner. Do not try to light the burner by hand.

B. **BEFORE OPERATING** smell all around the appliance area for gas. Be sure to smell next to the floor because some gas is heavier than air and will settle on the floor.

WHAT TO DO IF YOU DO SMELL GAS

- Do not try to light any appliance.
- Do not touch any electric switch; do not use any phone in your building.
- Immediately call your gas supplier from a neighbor's phone. Follow the gas supplier's instructions.

- If you cannot reach your gas supplier, call the fire department.

C. Use only your hand to turn the gas control valve. Never use tools. If the handle will not turn by hand, don't try to repair it, call a qualified service technician. Force or attempted repair may result in a fire or explosion.

D. Do not use this appliance if any part has been under water. Immediately call a qualified service technician to inspect the appliance and to replace any part of the control system and any gas control which has been under water.

OPERATING INSTRUCTIONS

1. **STOP!** Read the safety information above.
2. Set the thermostat to lowest setting.
3. Turn off all electric power to the appliance.
4. This appliance is equipped with an ignition device which automatically lights the burner. Do not try to light the burner by hand.
5. Turn gas shutoff valve(s) clockwise ☺ to "OFF". Handle will be perpendicular to pipe, do not force.

6. Wait five (5) minutes to clear out any gas. Then smell for gas, including near the floor. If you smell gas, **STOP!** Follow "B" in the safety information above on this label. If you don't smell gas, go to the next step.
7. Turn gas shutoff valve(s) counterclockwise ☹ to "ON". Handle will be in line with the pipe.
8. Turn on all electric power to appliance.
9. Set thermostat to desired setting.
10. If the appliance will not operate, follow the instructions "To Turn Off Gas To Appliance" and call your service technician or gas supplier.

Single Burner Models

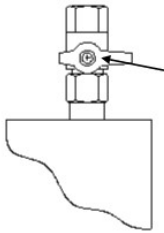

**Gas Control Knob(s)
(shown in the "OFF" position)**

Two Burner Models (Commercial)

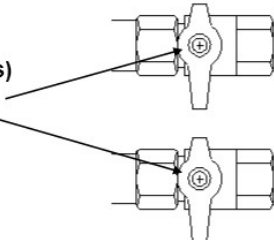

TO TURN OFF GAS TO APPLIANCE

1. Set the thermostat to lowest setting.
2. Turn off all electric power to the appliance if service is to be performed.

3. Turn the gas shutoff valve(s) clockwise ☹ "OFF". Handle will be perpendicular to pipe, do not force.

(PF)
9512 REV1

Figure 9.5: Lighting & Operating Instructions

10. TROUBLESHOOTING

A. BLOCKING ERRORS

1. When a Blocking Error occurs the controller will display a message and an "E" error code on the display module.
2. These error messages and several suggested corrective actions are included in Table 10.1.
3. Certain Blocking Errors will, if uncorrected, become Locking Errors as described in Paragraph B.

B. LOCKING ERRORS

1. When a Locking Error occurs the controller will display a message and an "A" error code on the display module.
2. These error messages and several suggested corrective actions are included in Table 10.2.
3. Press the **Reset** key to clear the Locking Error and resume operation. Be sure to observe the operation of the unit to prevent a recurrence of the fault.
4. The boiler control will retry for ignition after one hour of being in a lockout condition. This will prevent lockout errors from resulting in "No Heat" calls if there is an intermittent problem.
5. The control logs the flame signal four times during the last 2 seconds of the ignition period. This is to aid in troubleshooting ignition errors. A flame signal below 2 micro-amperes at the end of this period will result in a lockout. If the flame signal is low, remove the flame sensor and igniter for inspection. Also, be sure that the lead to the flame sensor is not grounded.

WARNING

Do not use this appliance if any part has been under water. Improper or dangerous operation may result. Contact a qualified service technician immediately to inspect the boiler and to repair or replace any part of the boiler which has been under water.

CAUTION

If overheating occurs or the gas supply fails to shut off, do not turn off electrical power to the circulating pump. This may aggravate the problem and increase the likelihood of boiler damage. Instead, shut off the gas supply to the boiler at the gas service valve.

CAUTION

Label all wires prior to disconnection when servicing controls. Wiring errors may cause improper and dangerous operation. Verify proper operation after servicing.

CAUTION

The convenience outlet is powered even when the service switch is off.

WARNING

When servicing or replacing any components of this boiler be certain that:

- The gas is off.
- All electrical power is disconnected.

DANGER

When servicing or replacing components that are in direct contact with the boiler water, be certain that:

- There is no pressure in the boiler. (Pull the release on the relief valve. Do not depend on the pressure gauge reading).
- The boiler water is not hot.
- The electrical power is off.

Table 10.1: Control Board Blocking Error Codes (automatic reset):

| "E" CODE | Error Display | Internal No. | Error Description | Corrective Action |
|----------|-------------------------------------|--------------|---|---|
| E01 | SUPPLY SENSOR NOT CONNECTED | 51 | Supply sensor not connected. | Check harness and sensor. |
| E02 | RETURN SENSOR NOT CONNECTED | 52 | Return sensor not connected. | Check harness and sensor. |
| E04 | DHW SENSOR NOT CONNECTED | 55 | DHW sensor not connected. | If DHW Mode is not intended to be set to Mode 1, DHW Store with Sensor, then change it to the appropriate Mode. Check harness and sensor. |
| E05 | STACK SENSOR OPEN | 57 | Flue gas sensor open. | Check vent temperature, harness, sensor. |
| E11 | SUPPLY SENSOR SHORT | 59 | Supply sensor shorted. | Check harness and sensor. |
| E12 | RETURN SENSOR SHORT | 60 | Return sensor shorted. | Check harness and sensor. |
| E13 | STACK SENSOR SHORT | 65 | Flue gas sensor shorted. | Check harness and sensor. |
| E14 | DHW SENSOR SHORT | 63 | DHW sensor shorted. | Check harness and sensor. |
| E19 | COMMUNICATION ERROR E2PROM ERROR | 0 | Problems reading from or writing to e2prom. | Contact PB Heat Representative. |
| E20 | FALSE FLAME DETECTED | 35 | False Flame detected. | Verify no flame in observation port. Check Sensor. |
| E21 | HOT/NEUTRAL REVERSED | 44 | Phase and neutral of mains supply are reversed. | Verify polarity of incoming wiring. Check boiler ground and harness. |
| E22 | POOR GROUND | 43 | No earth connected or internal hardware error. | Check boiler ground and harness. |
| E23 | NET FREQUENCY ERROR | 45 | Mains frequency differs more than 2% from 60Hz. | Contact electrical provider and/or an electrician. |
| E24 | POOR GROUND | 46 | Earth connection is not ok. | Check boiler ground and harness. |
| E25 | BLOCKED VENT | 38 | Blocked Vent Switch is Open | Check for blocked vent pipe or blocked heat exchanger. Check switch and tubing to switch. |
| E26 | BLOCKED CONDENSATE DRAIN | 41 | Condensate drain blocked. | Check condensate tanks, hoses, condensate switch, and harness. |
| E30 | HIGH STACK TEMPERATURE | 39 | Flue gas sensor above max flue setpoint + diff. | If flue pipe is hot, check flue temperature and compare to values shown Table 8.6. Check for proper gas input and combustion readings, check for dirty heat exchanger. If flue pipe is not hot, check flue sensor and harness. |
| E31 | LOW WATER | 36 | Water level is too low. | Check boiler water level, low water cut-off, harness. If a LWCO is not used, a jumper should be placed between terminals #9 and #10, LWCO Contact. |
| E32 | HIGH RETURN TEMP | 40 | Return temperature is above 194°F (90°C). | Check for reversed supply and return piping or pump installed backwards. |
| E42 | INTERNAL HDWRE ERROR | 47 | Internal hardware error. | Replace control. |
| E45 | INTERNAL HDWRE ERROR | 31 | Internal hardware error. | Replace control. |
| E46 | INTERNAL HDWRE ERROR | 32 | Internal hardware error. | Replace control. |
| E47 | INTERNAL HDWRE ERROR | 33 | Internal hardware error. | Replace control. |
| E48 | INTERNAL HDWRE ERROR | 34 | Internal hardware error. | Replace control. |
| E51 | RESET BUTTON ERROR PLEASE WAIT. | 66 | Reset button pressed more than 7 times within one minute. | Wait five minutes. If error does not clear, replace control. |

Table 10.2: Control Board Locking Error Codes (manual reset):

| "A" CODE | Error Display | Internal No. | Error Description | Corrective Action |
|----------|----------------------------------|--------------|---|---|
| A01 | IGNITION ERROR | 1 | Three consecutive unsuccessful ignition attempts. | <ol style="list-style-type: none"> 1. Watch the igniter through the observation window. 2. If no spark is present, check the spark electrode for the proper 3/16" gap. 3. Remove any corrosion from the spark electrode with abrasive. 4. If spark is present but no flame, check the gas supply to the boiler. Check for high or low pressure. 5. If there is a flame, check the flame signal ignition log in the Installer Menu. If values for flame signal are less than 3.1 μA, check wiring connections and clean the harness connector at the control. 6. Determine if gas valve is opening by monitoring gas pressure. 7. Check gas pressure. |
| A02 | FLAME FAILURE | 24 | Three consecutive flame failures during one demand. | <ol style="list-style-type: none"> 1. If boiler sparks, lights briefly and then goes out: <ol style="list-style-type: none"> a. Disconnect the flame sensor cable and then retry ignition.* b. If the flame stays lit, allow the boiler to run for several minutes and then reattach the cable.* c. If the problem persists, remove the flame sensor and inspect the burner through the sensor opening. If metal fibers are protruding from the burner, use a blunt probe to move the fibers away from the sensor. d. If the problem is still present, replace the flame sensor. 2. If the unit locks out on flame failure during normal operation: <ol style="list-style-type: none"> a. Check gas pressure at the inlet to the gas valve (See figure 5.2) while the boiler is operating. b. Check the flame signal in the Installer Menu under Status. This will also show the total number of flame failures. If the flame signal reads less than 2.8 μA, clean the sensor and igniter. Be sure that the wiring harness is fully seated at the control. c. If the flame signal is consistently low, check the signal with the sensor disconnected. If the flame signal improves, replace the flame sensor. |
| A03 | OVERHEAT LIMIT OPEN | 18 | High Temperature Limit Open [Set Temperature: 195°F (90.5°C)] | <ol style="list-style-type: none"> 1. Check pump operation. 2. Assure that there is adequate flow through the boiler by checking the status menu and assuring less than 40°F (4.4°C) temperature rise across the boiler. 3. Check thermistor reading on the supply thermistor. Replace it if necessary. |
| A04 | INTERNAL ERROR GAS VALVE RELAY | 5 | Gas Valve Relay Problems. | Replace control |
| A05 | INTERNAL ERROR SAFETY RELAY | 6 | Safety Relay Problems. | Replace Control |
| A09 | INTERNAL SOFTWARE ERR RAM ERROR | 9 | Internal Software Error. | Replace Control |
| A09 | INTERNAL SOFTWARE ERR | 27 | Internal Software Error. | Replace Control |
| A09 | INTERNAL SOFTWARE ERR | 28 | Internal Software Error. | Replace Control |
| A09 | INTERNAL SOFTWARE ERR | 29 | Internal Software Error. | Replace Control |
| A09 | INTERNAL SOFTWARE ERR | 30 | Internal Software Error. | Replace Control |
| A10 | COMMUNICATION ERROR E2PROM ERROR | 12 | No Communication with E2prom. | Replace Control |

* The flame is sensed through both the sensor and the igniter.

Table 10.2 (cont'd): Control Board Locking Error Codes (manual reset):

| "A" CODE | Error Display | Internal No. | Error Description | Corrective Action |
|----------|---|--------------|---|--|
| A12 | SOFTWARE OUT OF DATE E2PROM OUT OF DATE | 10 | Contents of e2prom is not up-to-date. | Replace Control |
| A13 | INTERNAL ERROR | 13 | Internal Software Error | Replace Control |
| A14 | INTERNAL ERROR | 14 | Internal Software Error | Replace Control |
| A15 | INTERNAL ERROR | 16 | Internal Software Error | Replace Control |
| A16 | INTERNAL ERROR | 22 | Internal Software Error | Replace Control |
| A18 | INTERNAL ERROR | 19 | Internal Software Error | Replace Control |
| A19 | FALSE FLAME DETECTED AFTER SHUTDOWN | 20 | Flame signal detected 10 sec. after closing the gas valve. | <ol style="list-style-type: none"> 1. Check flame sensor to be sure there is no short to ground. 2. Check igniter to be sure there is not short to ground. 3. This could also indicate that the gas valve doesn't close completely. |
| A20 | FALSE FLAME DETECTED BEFORE IGNITION | 21 | Flame signal detected before gas valve opened. | <ol style="list-style-type: none"> 4. Check flame sensor to be sure there is no short to ground. Check igniter to be sure there is not short to ground. |
| A23 | FLOW_SW_NOT_OPEN | 25 | CH flow switch not working. | <ol style="list-style-type: none"> 1. Check for electrical continuity between wires connected to terminals 9 & 10 from field supplied flow switch. 2. If there is continuity when the pump is off, there is a system piping or pump control problem. |
| A24 | FLOW_SW_NOT_CLOSED | 26 | CH flow switch not working. | <ol style="list-style-type: none"> 1. Check for electrical continuity between wires connected to terminals 9 & 10 from the field supplied flow switch. 2. If there is no continuity, check to be sure the pump is working. 3. If the pump is working correctly, check the flow switch. |
| A33 | FAN SPEED ERROR | 8 | Fan speed detected is more than 300 rpm different from targeted value for more than 60 seconds. | <ol style="list-style-type: none"> 1. Is the fan running at full speed? <ul style="list-style-type: none"> • Check 4 wire control connection to blower and control. • Replace harness. 2. Is the fan running at a modulated speed? <ul style="list-style-type: none"> • Check 4 wire control connection to blower and control. • Replace harness. 3. Is the fan not running? <ul style="list-style-type: none"> • Check the 3 wire power connection to the blower and control. • Replace harness. • Replace Blower. |
| A50 | RETURN HIGHER THAN SUPPLY | 11 | Boiler return water temperature higher than supply for more than 5 ignition attempts. | <ol style="list-style-type: none"> 1. Check system piping. Assure that the water is entering the return connection and exiting the supply connection. 2. Compare the supply thermistor reading to the temperature gauge, if they don't agree, replace the supply thermistor. |

C. WARNING ERRORS

The PureFire boiler control will display a blinking screen under several conditions. Several of these conditions provide the error information directly on the screen. Table 10.3 shows sensor errors and corresponding corrective actions.

DHW Sensor Error:

- a. If the boiler control is set to operate on DHW Mode 1 (DHW Sensor), and there is no sensor connected the boiler will not satisfy a DHW call for heat.
- b. The display will blink and the DHW temperature will read 14°F (-10°C) if there is an open circuit at the sensor terminals. Pressing the “Reset” key will display the following error screen.
- c. This will also occur if the wires are not properly

connected.

- d. If there is a short at the DHW sensor terminals and the DHW mode is set to Mode 1, the DHW system will not operate. The display will blink to indicate a warning error. Pressing the “Reset” key will display the following error screen.



Table 10.3: Control Board Warning Error Codes

| “W” CODE | Error Display | Error Description | Corrective Action |
|----------|---|-------------------|--|
| #W02 |  Blinking Screen – Press “Reset” key to view this message | DHW Sensor Open | 1) Be sure the DHW Tank Sensor (54157), provided with the boiler, is connected to terminals #5 & #6. 2) Remove the wires from terminals #5 and #6 on the boiler and check the resistance between them. <ul style="list-style-type: none"> a. If the resistance is above 10 k W, check the resistance at the sensor. b. If the reading at the sensor is the same, replace the sensor. c. If the reading at the sensor is lower, replace the wiring. |

11. MAINTENANCE

WARNING

Product Safety Information Refractory Ceramic Fiber Product

This appliance contains materials made from refractory ceramic fibers (RCF). Airborne RCF fibers, when inhaled, have been classified by the International Agency for Research on Cancer (IARC), as a possible carcinogen to humans. After the RCF materials have been exposed to temperatures above 1800°F (982°C), they can change into crystalline silica, which has been classified by the IARC as carcinogenic to humans. If particles become airborne during service or repair, inhalation of these particles may be hazardous to your health.

Avoid Breathing Fiber Particulates and Dust

Suppliers of RCF recommend the following precautions be taken when handling these materials:

Precautionary Measures:

Provide adequate ventilation.

Wear a NIOSH/MSHA approved respirator.

Wear long sleeved, loose fitting clothing and gloves to prevent skin contact.

Wear eye goggles.

Minimize airborne dust prior to handling and removal by water misting the material and avoiding unnecessary disturbance of materials.

Wash work clothes separately from others. Rinse washer thoroughly after use.

Discard RCF materials by sealing in an airtight plastic bag.

First Aid Procedures:

Inhalation: If breathing difficulty or irritation occurs, move to a location with fresh clean air. Seek immediate medical attention if symptoms persist.

Skin Contact: Wash affected area gently with a mild soap and warm water. Seek immediate medical attention if irritation persists.

Eye Contact: Flush eyes with water for 15 minutes while holding eyelids apart. Do not rub eyes. Seek immediate medical attention if irritation persists.

Ingestion: Drink 1 to 2 glasses of water. Do not induce vomiting. Seek immediate medical attention.

A. GENERAL (WITH BOILER IN USE)

General boiler observation can be performed by the owner. If any potential problems are found, a qualified installer or service technician/agency must be notified.

1. Remove any combustible materials, gasoline and other flammable liquids and substances that generate flammable vapors from the area where the boiler is contained.
2. Remove any corrosive chemicals that may be stored near the boiler. Chlorine, ammonia or similar products can be very aggressive in a combustion environment.
3. Observe general boiler conditions (unusual noises, vibrations, etc.)
4. Observe operating temperature and pressure on the combination gauge located in the supply piping on the left side of the boiler. Boiler pressure should never be higher than 5 psi below the rating shown on the safety relief valve (25 psig maximum for a 30 psig rating). Boiler temperature should never be higher than 240°F (116°C).
5. Check for water leaks in boiler and system piping.
6. Smell around the appliance area for gas. If you smell gas, follow the procedure listed in the Lighting Operating Instructions to shut down appliance in Section 9, Start-Up Procedure Part B.

B. WEEKLY (WITH BOILER IN USE)

Flush float-type low-water cut-off (if used) to remove sediment from the float bowl as stated in the manufacturer's instructions.

C. ANNUALLY (BEFORE START OF HEATING SEASON)

CAUTION

The following annual inspection must be performed by a qualified service technician.

1. Check boiler room floor drains for proper functioning.
2. Check function of the safety relief valve by performing the following test:
 - a. Check valve piping to determine that it is properly installed and supported.
 - b. Check boiler operating temperature and pressure.
 - c. Lift the try lever on the safety relief valve to the full open position and hold it for at least five seconds or until clean water is discharged.
 - d. Release the try lever and allow the valve to close. If the valve leaks, operate the lever two or three times to clear the valve seat of foreign matter. It may take some time to determine if the valve has shut completely.
 - e. If the valve continues to leak, it must be replaced before the boiler is returned to operation.
 - f. Check that operating pressure and temperature have returned to normal.
 - g. Check again to confirm that valve has closed completely and is not leaking.
3. Test low-water cut-off (if used) as described by the manufacturer.
4. Test limit as described in Section 9, Part D, "Check Operation".
5. Test function of ignition system safety shut-off features as described in Section 9, Part D, "Check Operation".
6. Remove the top/front jacket panel and inspect for

DANGER

When servicing or replacing components, be absolutely certain that the following conditions are met:

- Water, gas and electricity are off.
- The boiler is at room temperature.
- There is no pressure in the boiler.

CAUTION

The convenience outlet is powered even when the service switch is off.

any foreign debris that may have entered through air intake vent.

7. Remove burner plate for inspection of burner and coils. Refer to paragraph 11.E.1 for removal procedure.
8. With boiler in operation check that condensate is dripping from condensate tubing. Check for any restriction in condensate drain line.

D. CONDENSATE CLEANING INSTRUCTIONS

1. Removal of Condensate Tanks.
 - a. Close manual gas shutoff valve on top of boiler and turn off power to the boiler by placing the boiler service switch to the off position.
 - b. Remove the front jacket panel.
 - c. Remove the wing nut securing the front tank and disconnect the tank from the upper right drain hose. (Some condensate may spill out of this port).
 - d. Remove the cap from the tank and position a container in front of the boiler and tilt the tank to drain condensate into the container.
 - e. Tank and lower hose may be removed by disconnecting the lower hose from the rear tank.
 - f. Clean tank and hose with water and inspect the rear tank for sediment in the lower connection port. The rear tank can be removed for cleaning if required by removing the wing nut and disconnecting the two float switch wire leads. NOTE: Special care must be taken when removing the hoses from the top of the rear tank. They must be held secure and do not pull hoses downward and away from their upper connections to the heat exchanger and vent adapter.
 - g. After cleaning, replace tanks and reconnect hoses and wire leads to float switch. Fill the front tank with water and check for any leaks at connections.
 - h. Replace the front jacket panel, open the manual gas valve and place the boiler service switch to the on position.
2. Before re-starting the boiler follow the steps below:
 - a. Reconnect the thermostat wires.
 - b. Open the manual gas shutoff valve and reset the thermostats.
 - c. Observe the boiler function to make sure you see a condensate flow.
 - d. If you do not observe a condensate flow, repeat the above procedure.
3. If the problem is not corrected at this point, it is possible that there is a material deposit problem. Follow the Coil Cleaning Instructions (Subsection 9E) below to dissolve deposits and clean the heat exchanger.

WARNING

It is extremely important to make sure there is no blockage in the exhaust vent. Failure to do so may result in serious personal injury or death.

E. COMBUSTION CHAMBER COIL INSPECTION AND CLEANING INSTRUCTIONS

NOTICE

Significant deposits may be caused by the recirculation of flue gases, dirt in the combustion air, or poor fuel quality. Review Section 3: Venting of this manual for proper venting configuration.

Before beginning this procedure, you must have on hand the following items:

- a nylon or brass brush (not steel)
 - "Rydlyme" (recommended for best results) (available online www.rydlyme.com) or "CLR" (available at most hardware stores)
1. Shut the boiler down and access the heat exchanger using the following steps:
 - a. Close the manual gas shutoff valve and wait for the unit to be cool to the touch.
 - b. Disconnect the condensate piping from the outside connections (not from inside the boiler jacket) so the flow can be observed.
 - c. Disconnect compression nut on gas valve inlet and disconnect the gas valve electrical connector.
 - d. Remove the six 10 mm nuts from the burner plate assembly. Disconnect wire leads to the spark igniter and flame sensor. Disconnect two Molex plugs from blower motor.
 - e. Pull the entire burner plate towards you to access the heat exchanger coils.

NOTICE

Significant deposits on the heating surface may be the result of exhaust gases recirculating into the combustion air. If deposits are evident, review section 3 of this manual to be sure the exhaust vent is installed correctly.

2. Using a spray bottle filled with the recommended product "Rydlyme" or "CLR", spray liberally on the coils, making sure the solution penetrates and funnels down through the condensate hose. If the condensate hose is blocked, let the chemical penetrate for at least 15 minutes or until it drains.
3. Use the nylon or brass brush (do not use steel) and scrub coils to remove any buildup, then vacuum the debris from the coils.
4. Spray coils with clear water, making sure to confine the spray to the area being cleaned (try to avoid wetting the back ceramic wall of the unit). Flush the combustion chamber with fresh water. At this point, the boiler should be ready to power back up.

5. Reinstall the burner plate assembly using the following steps:
 - a. Inspect the inside of the heat exchanger for dirt and debris.
 - b. Install the burner plate assembly and replace the six 10 mm nuts. For Duo heat exchangers only, tighten nuts to 7Nm torque. Follow Figure 11.1 Duo Heat Exchanger Burner Door Tightening Pattern.

**Tightening Pattern
For DUO ONLY**

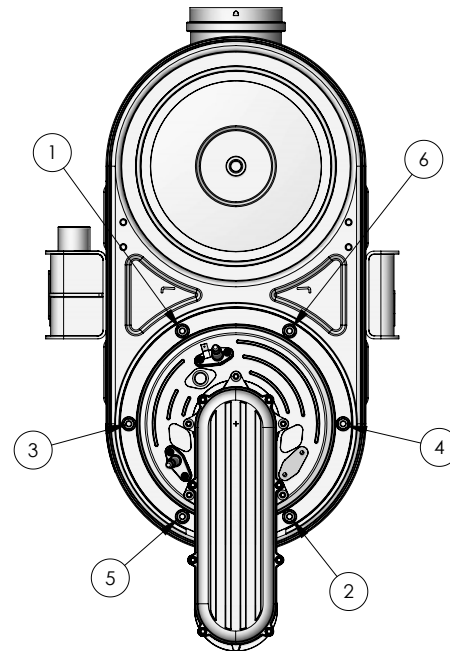

Figure 11.1 Duo Heat Exchanger Burner Door Tightening Pattern

- c. Reconnect the wire leads to the spark igniter, flame sensor and gas valve. (Be sure that the spark igniter is connected to the lead with the thick insulation.) Reconnect the two Molex® plugs on the blower motor.
- d. Connect the compression nut on the gas valve inlet and reattach the gas valve electrical connector.
- e. Reset thermostats. **(IMPORTANT: BE SURE THAT THE VENT CONNECTION IS NOT BLOCKED.)**

⚠ WARNING

It is extremely important to check for leaks when reconnecting the gas valve. Failure to do so may result in severe personal injury, death or major property damage.

- f. Turn the power to the boiler on. Observe the display module to assure proper operation.

- g. Initiate a call for heat** and observe the condensate flow.
- h. Reconnect the condensate piping to the drain connection.

****NOTE: When firing the boiler the first few times you may experience some fluttering of the gas burner that may result in a flame lockout. This is normal and will require you to recycle the unit until this clears up. This is caused by water still present in the combustion chamber.**

- 6. Inspect exhaust vent and air intake vents for proper support and joint integrity. Repair as necessary. Refer to Section 5, VENTING.

WARNING

Leaks in the vent system will cause products of combustion to enter structure (vent system operates under positive pressure).

- 7. Inspect exhaust vent and air intake vent terminations for obstructions or corrosion. Corrosion is an indication of exhaust gas recirculation.

12. BOILER DIMENSIONS & RATINGS

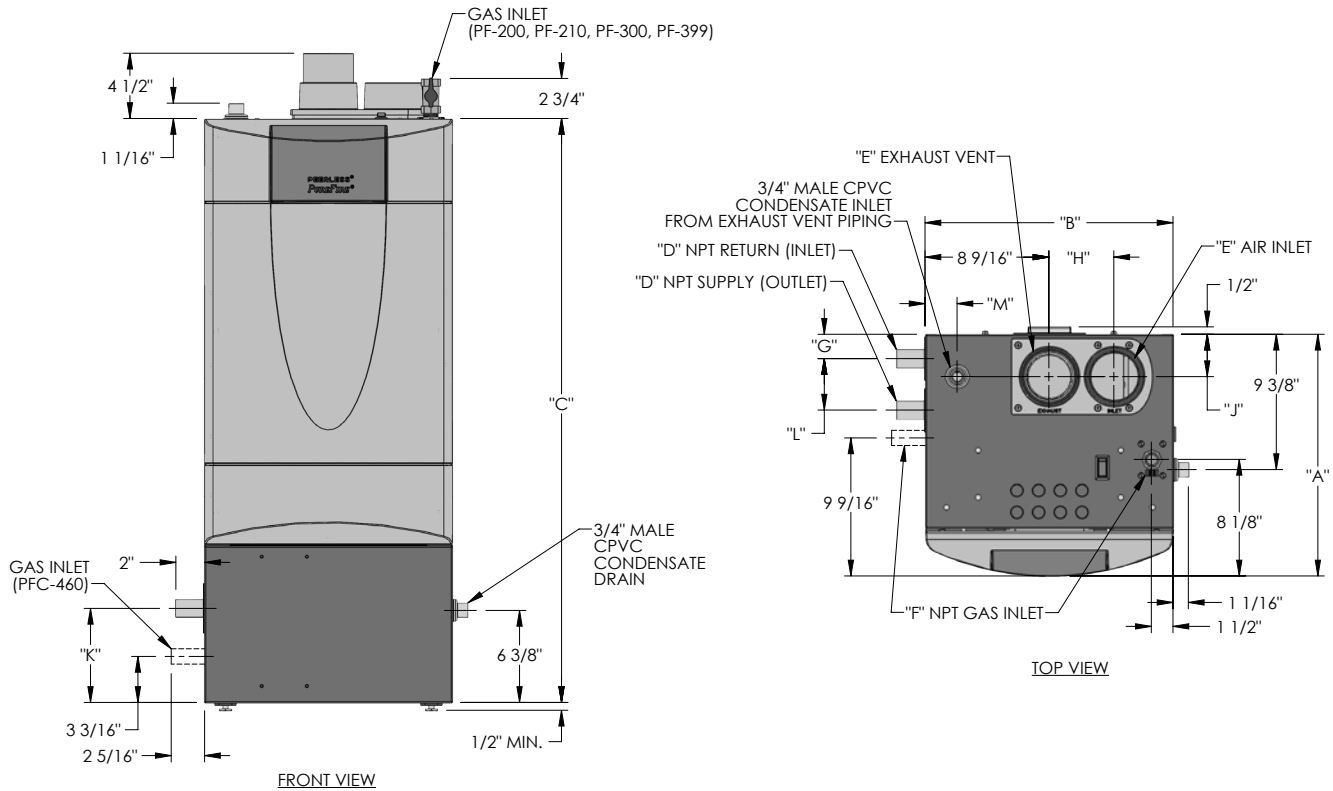

Figure 12.1: Dimensional Drawing

Table 12.1: Boiler Dimensions

| PUREFIRE® SERIES DIMENSIONS | | | | | | | | | | | |
|-----------------------------|-----------------------|----------------------|----------------------|-------------------|----------------|-----------------|-------------------|--------------------|-------------------|--------------------|---------------------|
| Boiler Model | "A" | "B" | "C" | "D" | "E" | "F" | "G" | "H" | "J" | "K" | "L" |
| PFW-200 | 16-9/16" (421 mm) | 17-3/16" (436 mm) | 40-1/2" (1029 mm) | 1" (25 mm) | 3" (76 mm) | 3/4" (19 mm) | 1-3/4" (44 mm) | 4-1/2" (114 mm) | 3" (76 mm) | 6-1/2" (165 mm) | 3-9/16" (90 mm) |
| PFW-399 | 27-15/16" (710 mm) | | | 1-1/2" (38 mm) | 4" (102 mm) | | 2-3/4" (70 mm) | 5-1/4" (133 mm) | 3-1/2" (89 mm) | 5-3/4" (146 mm) | 7-1/16" (179 mm) |

Table 12.2: Boiler Ratings

| PUREFIRE® SERIES BOILER RATINGS | | | | | |
|---------------------------------|----------------|-----------|---------------------------|---------------------|------------------------|
| Boiler Model | Input (MBH/kW) | | Heating Capacity (MBH/kW) | Net Rating (MBH/kW) | AFUE (%) |
| | Min. | Max. | | | |
| PFW-200 | 42/12.3 | 199/58.3 | 185/50.2 | 161/47.2 | 95.0 |
| | | | Gross Output (MBH/kW) | Net Rating (MBH/kW) | Thermal Efficiency (%) |
| PFW-399 | 80/23.4 | 399/116.9 | 380/111 | 330/96.7 | 95.2 |

BOILER DIMENSIONS & RATINGS

Table 12.3: Combustion Air Fan Speeds

| PUREFIRE® SERIES COMBUSTION AIR FAN SPEEDS | | | | |
|--|---------------------|-----------|----------|------------|
| Boiler Model | Input Rate (MBH/kW) | Fan Speed | | |
| | | Low Power | Ignition | High Power |
| PFW-200 | 199/58.3 | 1350 | 4650 | 5940 |
| PFW-399 | 399/116.9 | 1710 | 5790 | 7740 |

Table 12.4: PureFire® Main Control Specifications

| PUREFIRE® SERIES MAIN CONTROL SPECIFICATIONS | |
|--|--|
| Power Supply | 120 VAC Nominal (102-132 VAC) 60 Hertz Nominal (40-70 Hertz) |
| Fuse (5562) | 5 Amp, 250 VAC |
| Blower Voltage | 120 VAC |
| Gas Valve Voltage | 120 VAC |
| Thermostat Contacts | 24 VAC |
| DHW Contacts | 5 VDC |
| Flame Current Limits | Minimum (running): 2.8 µA Minimum (ignition): 3.1 µA Maximum: 10 µA |
| Temperature Sensors | NTC Thermistors are 12 kW @ 77°F (25°C) – 5 VDC Supply Sensor: 14°F (-10°C) to 244°F (118°C) Return Sensor : 14°F (-10°C) to 244°F (118°C) Flue Sensor: 50°F (10°C) to 280°F (138°C) DHW Sensor: 14°F (-10°C) to 244°F (118°C) |
| Listing Standards | Europe: CE EN298 North America: ANSI Z21.20 / CSA C22.2 |

Table 12.5: PureFire® Electrical Ratings

| PUREFIRE® SERIES COMBUSTION AIR FAN SPEEDS | | | | | | | | | |
|--|------------------------|-------|---------------|----------------|---------------|----------------|---------------|---------------------|---------------------------|
| Boiler Model | Supply Voltage Nominal | Freq. | Blower | | Gas Valve | | Pumps | | Max Total Service Current |
| | | | Voltage (VAC) | Current (amps) | Voltage (VAC) | Current (amps) | Voltage (VAC) | Max. Current (amps) | |
| PFW-200 | 120 VAC | 60 Hz | 120 | 2.58 | 120 | 0.09 | 120 | 20.00 | 22.67 |
| PFW-399 | | | | | | 0.21 | | | 22.79 |

13. REPAIR PARTS

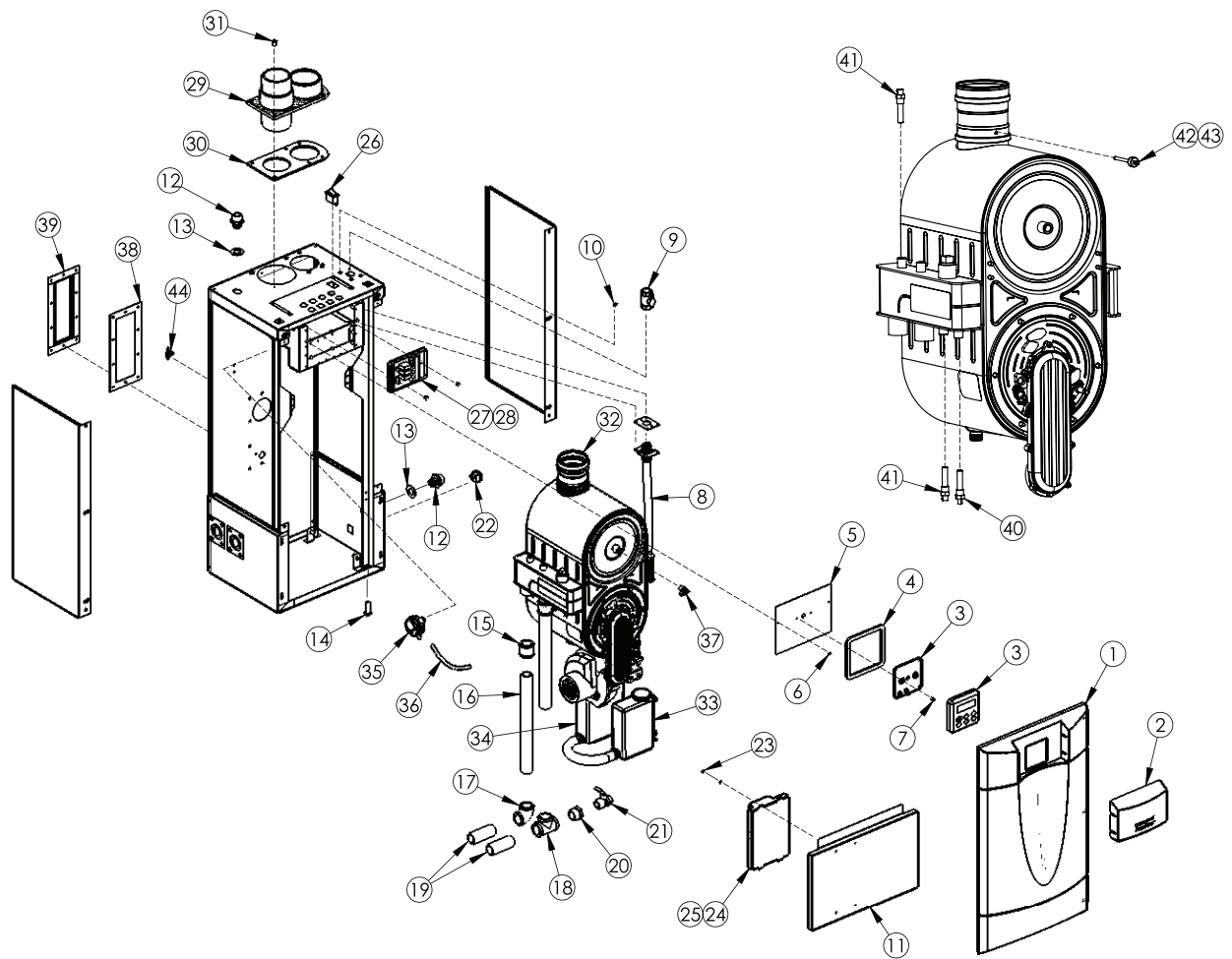

Figure 13.1: General Repair Parts

REPAIR PARTS

Table 13.1: General Repair Parts – PFW200 & PFW399

| | Description | Quantity | | Stock Code |
|----|--|----------|---------|------------|
| | | PFW-200 | PFW-399 | |
| 1 | Jacket Front Panel with Ball Studs (Provide Wiring Diagram Form No. when Ordering) | 1 | 1 | 54256 |
| 2 | Smoked Control Lens | 1 | 1 | 54167 |
| 3 | Display Module - PFW Boilers | 1 | 1 | 54650 |
| 4 | | 1 | 1 | 54153 |
| 5 | Display Bracket | 1 | 1 | PF2007-1 |
| 6 | #6-32 Keps Nut | 2 | 2 | 51553 |
| 7 | #6-32 x 1/2" Long Hex Head Screw | 2 | 2 | 5449 |
| 8 | Flexible Gas Line 3/4" | 1 | 1 | 54262 |
| 9 | Gas Line Gasket | 1 | 1 | 54142 |
| 10 | 3/4" NPT Manual Gas Shutoff Valve | 1 | 1 | 51805 |
| 11 | #10 x 1/2" Hex Head Sheet Metal Screw | 4 | 4 | 99992 |
| 12 | Lower Front Jacket Panel | 1 | 1 | PF6051 |
| 13 | Left Side Jacket Panel | 1 | | PF6049 |
| | Right Side Jacket Panel | 1 | 1 | PF6054 |
| | | | | PF6050 |
| | | | 1 | PF6055 |
| 14 | Bulkhead Fitting | 2 | 2 | 54140 |
| 15 | Bulkhead Fitting Gasket | 2 | 2 | 54134 |
| 16 | Leveling Leg | 4 | 4 | 5429 |
| 17 | 1" NPT Brass Coupling | 2 | | 5534 |
| | 1 1/2" NPT Brass Coupling | | 2 | 5551 |
| 18 | 1" NPT x 14 Brass Nipple | 2 | | 5557 |
| | 1 1/2" NPT x 14 Brass Nipple | | 2 | 5550 |
| 19 | 1" NPT Brass Elbow | 1 | | 5558 |
| | 1 1/2" NPT Brass Elbow | | 1 | 5553 |
| 20 | 1" NPT Brass Tee | 1 | | 5537 |
| | 1 1/2" NPT Brass Tee | | 1 | 5554 |
| 21 | 1" NPT x 3" Brass Nipple | 2 | | 5559 |
| | 1 1/2" NPT x 3" Brass Nipple | | 2 | 5552 |
| 22 | 1" NPT x 3/4" NPT Brass Reducing Bushing | 1 | | 5539 |
| | 1 1/2" NPT x 3/4" NPT Brass Reducing Bushing | | 1 | 5556 |
| 23 | 3/4" NPT Brass Drain Valve | 1 | 1 | 50756 |
| 24 | Convenience Outlet | 1 | 1 | 54136 |
| 25 | #8-32 Keps Nut | 4 | 4 | 51573 |
| 26 | Control Module - PFW-200 | 1 | | 54648 |
| | Control Module - PFW-399 | | 1 | 54287 |
| 27 | Rocker Switch (20 A, 120 VAC) | 1 | 1 | 5701 |
| 28 | Pump Isolation Relay Module | 1 | 1 | 54610 |
| 29 | 3" Exhaust Vent /Air Inlet Adapter - PFW-200 | 1 | | 54293 |
| | 4" Exhaust Vent / Air Inlet Adapter - PFW-399 | | 1 | 54294 |
| 30 | 3" Exhaust Vent Adapter Gasket - PFW-200 | | | 54133 |
| | 4" Exhaust Vent Adapter Gasket - PFW-399 | | | 54217 |
| 31 | #10 x 3/4" Phillips Pan Head Type A Screw | 6 | 6 | 5611 |
| 32 | 3" Heat Exchanger Outlet Collar - PFW-200 | 1 | | 5531 |
| | 4" Heat Exchanger Outlet Collar - PFW-399 | | 1 | 5532 |
| 33 | Condensate Neutralizer Assembly | 1 | 1 | 54204 |
| 34 | Condensate Receiver Assembly | 1 | 1 | 54259 |
| 35 | Blocked Vent Switch (includes items 36 & 37) | 1 | 1 | 54260 |
| 36 | 3/16" ID PVC Tubing x 12 " Long | 1 | 1 | 5563 |
| 37 | 90 Deg Barbed Elbow Adapter Fitting | 1 | 1 | 5698 |
| 38 | Thermal Fuse Cover Gasket | 1 | 1 | 54141 |
| 39 | Thermal Fuse Cover | 1 | 1 | PF2021 |
| - | Wiring Harness (includes Right Side Terminal Block, J2MN & J4/5RM Connectors) | 1 | 1 | 54629 |
| - | Wiring Harness (J6 Outputs to Relay Module) | 1 | 1 | 54627 |
| - | Wiring Harness (J7 Pump Output to Relay Module) | 1 | 1 | 54628 |
| - | Wiring Harness (Supply/Limit Adapter) | 1 | 1 | 54421 |
| - | Wiring Harness (Includes Left Side Terminal Block & J5/J16 Connectors) | 1 | 1 | PF7021 |
| - | Wiring Harness (Gas Valve/Flame Sensor Connectors) | 1 | 1 | PF7023 |
| - | Wiring Harness (Ground Wire) | 1 | 1 | PF7024 |
| - | 10 Pole Terminal Block Push-On Connector | 1 | 1 | 5450 |
| - | 6 Pole Terminal Block Push-On Connector | 1 | 1 | 5547 |
| - | Ignition Cable | 1 | 1 | 54115 |
| - | Relief Valve - 125 PSI | 1 | 1 | 54274 |
| - | 12 kΩ Flue Sensor | 1 | 1 | 54209 |
| - | Flue Sensor Grommet | 1 | 1 | 54291 |
| - | High Limit Switch | 1 | 1 | 54419 |
| - | 12 kΩ Supply/Return Sensor | 1 | 1 | 54418 |
| - | 12 kΩ Tank Temperature Sensor | 1 | 1 | 54157 |

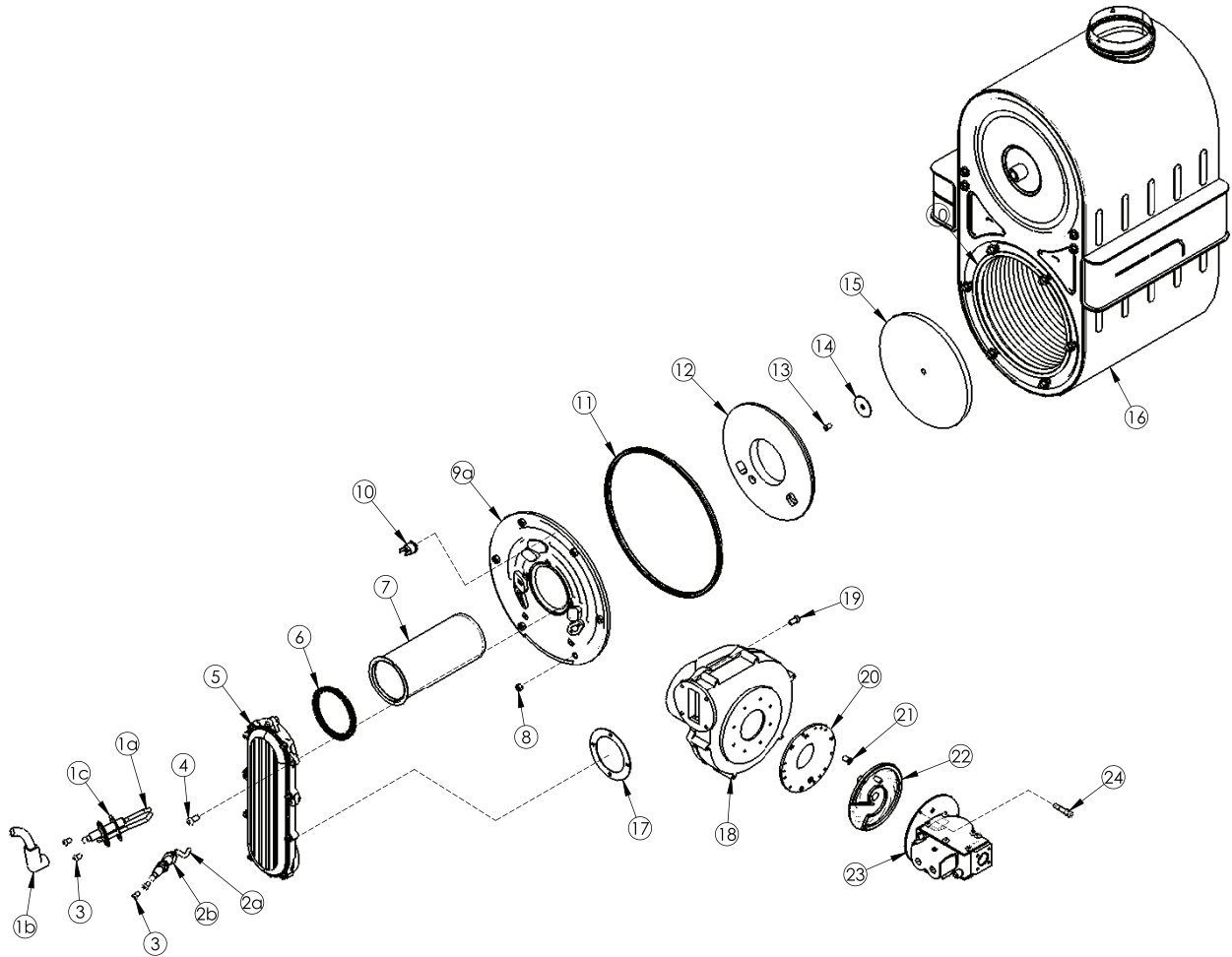

Figure 13.2: Heat Exchanger/Burner Assembly Repair Parts

REPAIR PARTS

Table 13.2: Heat Exchanger/Burner Assembly Repair Parts

| | Description | Quantity | | Stock Code |
|----|---|----------|---------|------------|
| | | PFW-200 | PFW-399 | |
| 1 | Ignitor with Gasket | 1 | 1 | 54246 |
| 2 | Sensor with Gasket | 1 | 1 | 54247 |
| 3 | M4 x 8 mm Screw | 4 | 4 | |
| 4 | M5.5 x 14 mm Screw Fine Thread (0.5) | 5 | 5 | |
| 5 | Premix Channel - PFW-200 | 1 | | 54249 |
| | Premix Channel - PFW-399 | | 1 | 54250 |
| 6 | Burner Gasket | 1 | 1 | 54186 |
| 7 | Premix Burner Element - PFW-200 | 1 | | 54263 |
| | Premix Burner Element - PFW-399 | | 1 | 54264 |
| 8 | M6 Nut (Fine Thread) | 6 | 6 | |
| 9 | Combustion Chamber Cover Plate (includes #10 & #12) | 1 | 1 | 54248 |
| 10 | Fiberglass Rope Gasket | 1 | 1 | 54188 |
| 11 | Gasket Rubber | 1 | 1 | 54187 |
| 12 | Combustion Chamber Cover Plate Insulation | 1 | 1 | 54255 |
| 13 | M4 x 8 mm Stainless Steel Screw | 1 | 1 | |
| 14 | M4 Stainless Steel Fender Washer | 1 | 1 | |
| 15 | Target Wall Insulation | 1 | 1 | 54185 |
| 16 | Heat Exchanger - PFW-200 | 1 | | 98103 |
| | Heat Exchanger - PFW-399 | | 1 | 98104 |
| 17 | Blower Outlet Gasket | 1 | 1 | 54122 |
| 18 | Combustion Air Blower - PFW-200 | 1 | | 54258 |
| | Combustion Air Blower - PFW-399 | | 1 | 54257 |
| 19 | M5 x 12 mm Screw | 4 | 4 | |
| 20 | Blower Adapter Plate - PFW-200 | 1 | | 5421 |
| | Blower Adapter Plate - PFW-399 | | 1 | 5610 |
| 21 | M4 x 10 mm Screw | 3 | 3 | |
| 22 | Swirl Plate - PFW-200 | 1 | | 54251 |
| | Swirl Plate - PFW-399 | | 1 | 54252 |
| 23 | Gas Valve - PFW-200 (includes #22 & #24) | 1 | | 54253 |
| | Gas Valve - PFW-399 (includes #22 & #24) | | 1 | 54254 |
| 24 | M4 x 25 mm Screw (PFW-200) | 3 | | |
| | M4 x 30 mm Screw (PFW-399) | | 3 | |



Figure 13.3: Concentric Horizontal Vent Termination



Figure 13.4: Concentric Vertical Vent Termination



Figure 13.5: Polypropylene Adapter

Table 13.3: Optional Exhaust Vent Termination Kits

| | Description | Quantity | | Stock Code |
|---|--|----------|---------|------------|
| | | PFW-200 | PFW-399 | |
| - | 3" Concentric Sidewall Termination Kit (PolyPro 3PPS-HK) | • | | 54498 |
| - | 4" Concentric Sidewall Termination Kit (PolyPro 4PPS-HK) | | • | 54499 |
| - | 3" Concentric Vertical Termination Kit (PolyPro 3PPS-VK) | • | | 54500 |
| - | 4" Concentric Vertical Termination Kit (PolyPro 4PPS-VK) | | • | 54501 |

Table 13.4: Optional Polypropylene Exhaust System Adapters





| | Description | Quantity | | Stock Code |
|---|--|----------|---------|------------|
| | | PFW-200 | PFW-399 | |
| - | 3" Polypropylene Vent/Inlet Adapter (Innoflue ISAGL0303) | • | | 54632 |
| - | 4" Polypropylene Vent/Inlet Adapter (Innoflue ISAGL0404) | | • | 54633 |
| - | 3" Polypropylene Vent/Inlet Adapter (PolyPro 3PPS-AD) | • | | 54630 |
| - | 4" Polypropylene Vent/Inlet Adapter (PolyPro 4PPS-AD) | | • | 54631 |

APPENDIX A. STATUS SCREENS

| Initialization & Standby | |
|--|--|
| P E E R L E S S P U R E F I R E V H W - - i n i t i a l i z i n g - - V e r s i o n [x x x x] | <p><u>PureFire Hot Water Supply Boiler Initialization Screen:</u> When power is first applied to the boiler the initialization screen is displayed. The software version of the display is represented by “xxxx” and is typically an alphanumeric checksum in hexadecimal format.</p> |
| D H W D i s a b l e d 1 6 : 3 6 S T A N D B Y T a n k : 7 0 ° F | <p><u>Boiler Standby Display:</u> An open circuit between terminal #1 & #2 on the boiler terminal strips will result in “DHW Disabled” displaying at the top of the screen. Since the default demand mode of the control is to use a domestic water sensor to initiate a demand, any temperature below the setpoint will result in the boiler starting. By adding a switch to terminals #1 & #2, the boiler may be disabled, allowing adjustment of the control parameters without the boiler operating. When the boiler is enabled, the screen will display tank temperature if the default demand mode (Mode 1) is used in conjunction with the tank temperature sensor (provided with the boiler). If the demand mode is switched to the “Tank with Thermostat” (Mode 2), the supply temperature is displayed on the screen.</p> |
| S T A N D B Y T a n k : 1 2 5 ° F | |
| S T A N D B Y S u p p l y : 1 4 2 ° F | |
| Ignition Sequence | |
| 1 6 : 3 6 D O M E S T I C H O T W A T E R T r i a l f o r I g n i t i o n T a n k : 1 2 5 ° F | <p><u>Trial for Ignition:</u> The temperature display depends on the demand mode of the boiler control. Tank temperature is displayed for the default demand mode, DHW Tank with Sensor (Mode 1) and supply temperature is displayed for DHW Tank with Thermostat (Mode 2). When a demand is initiated either by a temperature drop in the storage tank (Mode 1) or by a thermostat contact closure (Mode 2) the boiler displays “Trial for Ignition” as the blower begins to run. After ignition (spark, flame and flame sense), the control stabilizes the flame at the ignition speed (between 65% and 75% of modulation) for several seconds. After stabilization, the control modulates with respect to the target temperature (tank or supply). If the flame signal is lost before the flame stabilization period is complete, an ignition failure results. If the flame signal is lost after this stabilization, a flame failure results. The boiler circulator should always operate while the burner is firing.</p> |
| 1 6 : 3 6 D O M E S T I C H O T W A T E R T r i a l f o r I g n i t i o n S u p p l y : 1 4 2 ° F | |
| 1 6 : 3 6 D O M E S T I C H O T W A T E R 7 0 % T a n k : 1 2 8 ° F | |
| 1 6 : 3 6 D O M E S T I C H O T W A T E R 1 0 0 % S u p p l y : 1 3 2 ° F | |

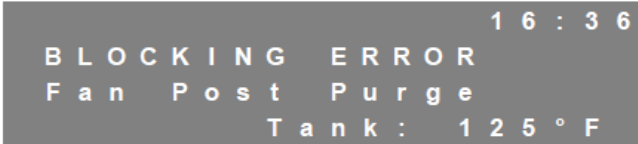
| Ignition Failure / Flame Failure | |
|--|--|
| <div style="background-color: #cccccc; padding: 5px;"> <p style="text-align: right;">1 6 : 3 6</p> <p>NO IGNITION</p> <p>Fan Post Purge</p> <p style="text-align: right;">Tank : 1 2 5 ° F</p> </div> | <p>Ignition Retry: If the burner fails to ignite (due to lack of ignition spark, failure to ignite the burner, or failure to sense the flame), the control will post purge for 30 seconds and then attempt to light the burner again. The display will show, NO IGNITION as shown. Similarly, if the flame is not sensed, the control will post purge for 30 seconds and attempt to re-light the burner. When the control is attempting to re-light the burner, the screen will display ignition retry. After 3 ignition attempts, the control will lock out. The control will stay in lockout for 1 hour before attempting to ignite the burner again.</p> |
| <div style="background-color: #cccccc; padding: 5px;"> <p style="text-align: right;">1 6 : 3 6</p> <p>FLAME FAILURE</p> <p>Fan Post Purge</p> <p style="text-align: right;">Tank : 1 2 5 ° F</p> </div> | |
| <div style="background-color: #cccccc; padding: 5px;"> <p style="text-align: right;">1 6 : 3 6</p> <p>DOMESTIC HOT WATER</p> <p>Ignition Retry</p> <p style="text-align: right;">Tank : 1 2 5 ° F</p> </div> | |
| Satisfied Demand | |
| <div style="background-color: #cccccc; padding: 5px;"> <p style="text-align: right;">1 6 : 3 6</p> <p>DOMESTIC HOT WATER</p> <p>Fan Post Purge</p> <p style="text-align: right;">Tank : 1 4 5 ° F</p> </div> | <p>Demand Satisfied: Using DHW Mode 1, when the tank reaches its setpoint plus 4°F fixed differential, the control will close the gas valve and purge the combustion chamber with the combustion blower for 30 seconds. During the fan post purge, the screen will display “DOMESTIC HOT WATER” and “Fan Post Purge” as shown. After the fan post purge, the boiler pump will remain running for the pump post purge period while showing “Circulator On”. If the boiler supply temperature increases above the setpoint plus the differential (both DHW Mode 1 & 2), the control will close the gas valve and purge the combustion chamber with the combustion blower for 30 seconds. During the fan post purge, the screen will display “SUPPLY AT SETPOINT” and “Fan Post Purge” as shown. Again, after the fan post purge the boiler pump will continue to run for the pump post purge period. “Circulator On” is displayed below “SUPPLY AT SETPOINT” during this period.</p> |
| <div style="background-color: #cccccc; padding: 5px;"> <p style="text-align: right;">1 6 : 3 6</p> <p>DOMESTIC HOT WATER</p> <p>Circulator On</p> <p style="text-align: right;">Tank : 1 4 5 ° F</p> </div> | |
| <div style="background-color: #cccccc; padding: 5px;"> <p style="text-align: right;">1 6 : 3 6</p> <p>SUPPLY AT SETPOINT</p> <p>Fan Post Purge</p> <p style="text-align: right;">Supply : 1 8 2 ° F</p> </div> | |
| <div style="background-color: #cccccc; padding: 5px;"> <p style="text-align: right;">1 6 : 3 6</p> <p>SUPPLY AT SETPOINT</p> <p>Circulator On</p> <p style="text-align: right;">Supply : 1 8 2 ° F</p> </div> | |
| Special Demand Functions | |
| <div style="background-color: #cccccc; padding: 5px;"> <p style="text-align: right;">1 6 : 3 6</p> <p>DOMESTIC HOT WATER</p> <p>Freeze Protection</p> <p>1 % Tank : 4 1 ° F</p> </div> | <p><u>Freeze Protection:</u> If the supply or return temperature drops below the freeze protection setpoint, the boiler pump is activated. If the temperature continues to drop by more than 9°F (5°C) the burner fires at its minimum power (1% of modulation) and continues until the return temperature increases by 18°F (10°C).</p> <p><u>Store Warm Hold:</u> Using DHW Mode 1, if the tank sensor temperature drops by 4°F (2°C) the boiler will run at minimum power until the tank temperature recovers. If the tank temperature continues to drop, the boiler will operate normally to reach the tank setpoint.</p> |
| <div style="background-color: #cccccc; padding: 5px;"> <p style="text-align: right;">1 6 : 3 6</p> <p>DOMESTIC HOT WATER</p> <p>Store Warm Hold</p> <p>1 % Tank : 1 1 5 ° F</p> </div> | |

APPENDIX A. STATUS SCREENS

| Error Handling | |
|--|--|
|  | <p>Blocking Error: A condition that prevents the boiler from operating but does not result in a control lockout is called a “Blocking Error”. In this case, the control will reset automatically once the condition is corrected. Open Supply Sensor, Poor Ground and Blocked Condensate Drain are examples of blocking errors. A complete list of blocking errors is listed in Table 10.1.</p> <p>Lockout Alarm: A condition that results in a control lockout, requiring a manual reset of the control is a “Lockout Alarm”. After the condition causing the alarm is corrected, the Reset key on the display module must be pressed in order to continue operation. Overheat Temperature Limit, Fan Speed Error and Flame Failure are examples of Lockout Alarms.</p> |
|  | |
|  | |
|  | |
| Service Notification | |
|  | <p>Service Indicator: Predetermined service intervals can be set on the control to prompt the end user to call for routine service. This interval can be set to “DATE”, “HOURS” or “CYCLES” in the installer menu.</p> |

APPENDIX B. USER MENU

| USER MENU | | | | | | | | | | | | | | | | | |
|--|---|--------------|--------------|---------|---------|--------|-----------|-------------|-------------|---------------|-------------|--------------|--------------|-----------------|-------------|--------------|--------------|
| <pre> MENU → Status Settings Messages </pre> | <p>The user menu is accessed by pressing the Menu Key. Use the ↑ and ↓ keys to identify the desired selection. Then press the Select key to choose the option.</p> | | | | | | | | | | | | | | | | |
| <pre> STATUS Current Tank Setpoint 120 °F ▼ </pre> | <p>Depending on which DHW Mode is selected in the Installer Menu (See Appendix C), either the tank temperature setpoint (DHW Mode 1) or the boiler supply (outlet) water temperature is shown. Pressing the ↓ key displays the current temperature readings from the boiler supply (outlet), boiler return (inlet) and DHW. In DHW Mode 2, either CALL or NO CALL is shown depending on the status of the DHW contacts. Pressing the ↓ key again displays the current temperature readings from the System and Vent Temperature Sensors. The final screen under the Status menu shows the status of the output to the DHW/Boiler Circulator (General Circulator) and the 3-Way Valve/Tank Circulator (DHW Circulator).</p> | | | | | | | | | | | | | | | | |
| <pre> STATUS Current Supply Setpoint 160 °F ▼ </pre> | | | | | | | | | | | | | | | | | |
| <pre> STATUS Supply 160 °F Return 130 °F DHW 120 °F ▼ </pre> | | | | | | | | | | | | | | | | | |
| <pre> STATUS System 160 °F Vent 180 °F ▼ </pre> | | | | | | | | | | | | | | | | | |
| <pre> STATUS General Circ Off DHW Circulator Off </pre> | | | | | | | | | | | | | | | | | |
| Settings – Storage Tank with Temperature Sensor (DHW Mode 1) | | | | | | | | | | | | | | | | | |
| <pre> SETTINGS DHW Supply Offset Offset: 18 °F Boiler SP: 158 °F ▼ </pre> | <p>The DHW Supply Offset is applied to the DHW Tank Setpoint if the control is configured for a storage tank with a temperature sensor (DHW Mode 1). For example, if the DHW Tank Setpoint is 140°F, an 18°F Offset will be added to 140°F for a Boiler Setpoint (SP) of 158°F. If the DHW tank setpoint is increased, the Offset value will be added until the total exceeds 194°F. The control uses the Boiler SP value to modulate the burner input.</p> <table border="1" data-bbox="824 1465 1461 1581"> <thead> <tr> <th>Parameter</th> <th>Minimum</th> <th>Default</th> <th>Maximum</th> </tr> </thead> <tbody> <tr> <td>Offset</td> <td>0°F (0°C)</td> <td>18°F (10°C)</td> <td>36°F (20°C)</td> </tr> <tr> <td>Tank Setpoint</td> <td>50°F (10°C)</td> <td>140°F (60°C)</td> <td>194°F (90°C)</td> </tr> <tr> <td>Boiler Setpoint</td> <td>50°F (10°C)</td> <td>180°F (82°C)</td> <td>194°F (90°C)</td> </tr> </tbody> </table> | Parameter | Minimum | Default | Maximum | Offset | 0°F (0°C) | 18°F (10°C) | 36°F (20°C) | Tank Setpoint | 50°F (10°C) | 140°F (60°C) | 194°F (90°C) | Boiler Setpoint | 50°F (10°C) | 180°F (82°C) | 194°F (90°C) |
| Parameter | | Minimum | Default | Maximum | | | | | | | | | | | | | |
| Offset | 0°F (0°C) | 18°F (10°C) | 36°F (20°C) | | | | | | | | | | | | | | |
| Tank Setpoint | 50°F (10°C) | 140°F (60°C) | 194°F (90°C) | | | | | | | | | | | | | | |
| Boiler Setpoint | 50°F (10°C) | 180°F (82°C) | 194°F (90°C) | | | | | | | | | | | | | | |
| <pre> SETTINGS DHW Tank Setpoint 140 °F ▼ </pre> | | | | | | | | | | | | | | | | | |
| Settings – Storage Tank with Thermostat (DHW Mode 2) | | | | | | | | | | | | | | | | | |
| <pre> SETTINGS DHW Supply Setpoint 180 °F ▼ </pre> | <p>If the control is configured for a storage Tank with a thermostat (DHW Mode 2), the control uses the boiler supply (outlet) temperature to modulate the burner input.</p> | | | | | | | | | | | | | | | | |

| Time Settings & Units | |
|---|--|
| <pre> SETTINGS ▲ Time & Date Monday 10 Jan 2014 21:12 ▼ </pre> | <p>The final two screens are used to set the time on the boiler display and to set the units (°F or °C). All of the settings available in the User menu are covered in more detail in Section 8.B.</p> |
| <pre> SETTINGS ▲ Temperature Units Fahrenheit °F </pre> | |
| Messages | |
| <pre> Last Lock A01 01 20 Hrs Ago Ignit Error ▼ Last Block E13 02 ▲ 5 Day Ago STACK SENSOR SHORT </pre> | <p>The messages selection of the User Menu displays the last Lockout Alarm (Screen 1) and the last Blocking Error (Screen 2). These messages show the error codes (A## and E##) along with English language descriptions of the errors. In addition, both of these screens provide the length of time since the last Lockout or Blocking Error occurred.</p> |

APPENDIX C. INSTALLER MENU

| | |
|--|--|
| INSTALLER MENU | |
| <pre> INSTALLER MENU → Status Boiler Settings Service Notif. System Test Cascade Settings Default </pre> | <p>The installer menu is accessed by simultaneously pressing the Menu and Select Key and holding them for 5 seconds. Use the ↑ and ↓ keys to identify the desired selection. Then press the Select key to choose the desired option.</p> |
| STATUS - Setpoint | |
| <pre> STATUS 1 Current Tank Setpoint 120 °F ▼ </pre> | <p>Depending on the DHW Mode, the current setpoint for either the tank or boiler supply is displayed on status screen #1. In the default, DHW Mode 1, when using a tank sensor, the tank target temperature (setpoint) can be viewed. In DHW Mode 2, where no tank sensor is connected, the target supply water temperature is displayed. These values can be changed in the user menu under settings. See Appendix B for information on setting these values.</p> |
| <pre> STATUS 1 Current Supply Setpoint 158 °F ▼ </pre> | |
| STATUS – Fan Speed | |
| <pre> STATUS 2 ▲ Fan Speed Current 0 RPM Low Power 1350 RPM ▼ </pre> | <p>Status screen #2 & #3 display fan speed information for the boiler. The current is the speed at which the blower is currently rotating. The low power, ignition, and high power fan speeds are fixed for a given boiler size. The low power fan speed is the minimum speed the blower should run and the high power fan speed is the maximum. The ignition speed is the speed the blower should run during the trial for ignition & in during the flame stabilization period. These values can be compared to those listed in Table 12.3.</p> |
| <pre> STATUS 3 ▲ Fan Speed Ignition 4650 RPM Hi Power 5940 RPM ▼ </pre> | |

| STATUS – Flame Signal / Flame Failures / Ignition Attempts | |
|---|---|
| <pre> STATUS 4 ▲ Flame Signal 9 . 6 μ A Flame Failures 0 ▼ </pre> | <p>Status screen #4 shows the current flame signal and the total flame failures that have occurred with the boiler control. Note that there is typically a time lag when reporting this value so the flame signal may be deceiving when troubleshooting during the ignition cycle.</p> <p>Therefore, screen #5 and #6 log measure #1-#4 which record the flame signal at ½ second increments during the last 2 seconds of the trial-for-ignition period. This is useful to identify problems with flame sensing during the ignition period. The minimum flame signal value to allow the burner to advance into the burn state is 3.1 μA. Once ignition is complete, a flame signal below 2.8 μA will result in a flame failure.</p> <p>Status screen #7 shows the total number of successful and failed ignition attempts. Note that the non-volatile memory only records increments of 3 failures, therefore if the power is cycled in between these failures, the failed ignitions will not be included in the total.</p> |
| <pre> STATUS 5 ▲ Flame Meas . 1 2 . 5 μ A Flame Meas . 2 3 . 8 μ A ▼ </pre> | |
| <pre> STATUS 6 ▲ Flame Meas . 3 6 . 2 μ A Flame Meas . 4 6 . 5 μ A ▼ </pre> | |
| <pre> STATUS 7 ▲ Ignition Attempts Successful 1 2 0 0 Ignition Attempts Failed 1 ▼ </pre> | |
| STATUS – Run Time | |
| <pre> STATUS 8 ▲ Boiler Run Time 7 0 0 H R ▼ </pre> | <p>Status screen #8 shows the total run time of the boiler control. The boiler run time records the total hours that a demand is present on the boiler.</p> |
| STATUS – Blocking Errors / Lockout Alarms | |
| <pre> STATUS # E 2 6 9 ▲ 2 Day Ago BLOCKED CONDENSATE DRAIN ▼ </pre> | <p>Status screen # 9 shows the last blocking error and the time since it occurred. The code number is shown at the top of the screen and its corresponding description is shown in English at the bottom. The last 16 blocking errors can be reviewed by pressing the Select and using the ▲ key to advance through the error history log. The number of the error, starting from 0 which indicates the last error (noted in the upper right corner) is incremented in reverse order of occurrence. The period of time “to prev. Block” indicates the time between the error and the one before it.</p> <p>Status screen #10 shows the last lockout alarm and the time since it occurred. Pressing the Select and using the ▲ key will advance through the lockout alarm history log.</p> <p>Refer to Table 10.1 for a list of blocking errors and Table 10.2 for a list of lockout alarms.</p> |
| <pre> STATUS # E 0 1 1 5 Day to prev. Block DHW SENSOR NOT CONNECTED </pre> | |
| <pre> STATUS # A 0 2 1 0 ▲ 16 Hrs Ago FLAME FAILURES </pre> | |
| <pre> STATUS # A 0 2 1 38 Min to prev. Lock FLAME FAILURES </pre> | |

BOILER SETTINGS – DHW (Domestic Hot Water)

| <p>BOILER SETTINGS 1 DHW mode MODE: 1 DHW Store with Sensor ▼</p> | <p>Boiler settings screen #1 is used for selecting the DHW Mode. The default value of DHW Mode 1 requires the installer to use the tank sensor (provided) to monitor the storage tank directly. Boiler setting screen #2 is for selecting the maximum post purge time of the DHW pump. This time is limited by the value selected for supply/return differential on screen #3, which will stop the post purge once the supply and return temperature are within this temperature difference.</p> <table border="1"> <thead> <tr> <th>Parameter</th> <th>Minimum</th> <th>Default</th> <th>Maximum</th> </tr> </thead> <tbody> <tr> <td>DHW Mode</td> <td>1</td> <td>1</td> <td>2</td> </tr> <tr> <td>Max Post Purge</td> <td>0</td> <td>60 sec</td> <td>255 sec</td> </tr> <tr> <td>TDiff</td> <td>0°F (0°C)</td> <td>4°F (2°C)</td> <td>18°F (10°C)</td> </tr> </tbody> </table> | Parameter | Minimum | Default | Maximum | DHW Mode | 1 | 1 | 2 | Max Post Purge | 0 | 60 sec | 255 sec | TDiff | 0°F (0°C) | 4°F (2°C) | 18°F (10°C) |
|---|---|-----------|-------------|---------|---------|----------|---|---|---|----------------|---|--------|---------|-------|-----------|-----------|-------------|
| Parameter | | Minimum | Default | Maximum | | | | | | | | | | | | | |
| DHW Mode | | 1 | 1 | 2 | | | | | | | | | | | | | |
| Max Post Purge | 0 | 60 sec | 255 sec | | | | | | | | | | | | | | |
| TDiff | 0°F (0°C) | 4°F (2°C) | 18°F (10°C) | | | | | | | | | | | | | | |
| <p>BOILER SETTINGS 2 ▲ Max DHW Pump Post Purge Time 60 sec ▼</p> | | | | | | | | | | | | | | | | | |
| <p>BOILER SETTINGS 3 ▲ Supply Return TDiff 4 ° F ▼</p> | | | | | | | | | | | | | | | | | |

BOILER SETTINGS – Vent Limit Temperature Selection

| <p>BOILER SETTINGS 4 ▲ Installation Location USA ▼</p> | <p>The values selected on boiler setting screens #4 & #5 are used to determine the vent temperature limit. Choosing the location in screen #4 reflects differences in national codes for this function. The vent material, selected from screen #5, reflects the material properties of various approved vent materials.</p> <table border="1"> <thead> <tr> <th>Parameter</th> <th>Choices</th> <th>Default</th> </tr> </thead> <tbody> <tr> <td>Installation Location</td> <td>USA /Canada</td> <td>USA</td> </tr> <tr> <td>Vent Material</td> <td>PVC / CPVC / Polypropylene / Stainless Steel</td> <td>PVC</td> </tr> </tbody> </table> | Parameter | Choices | Default | Installation Location | USA /Canada | USA | Vent Material | PVC / CPVC / Polypropylene / Stainless Steel | PVC |
|--|---|-----------|---------|---------|-----------------------|-------------|-----|---------------|--|-----|
| Parameter | | Choices | Default | | | | | | | |
| Installation Location | USA /Canada | USA | | | | | | | | |
| Vent Material | PVC / CPVC / Polypropylene / Stainless Steel | PVC | | | | | | | | |
| <p>BOILER SETTINGS 5 ▲ Vent Material: PVC ▼</p> | | | | | | | | | | |

BOILER SETTINGS – Freeze Protection /Additional Safety Function / Blower Post Purge

| <p>BOILER SETTINGS 6 ▲ Freeze Protection starts at: 50 ° F ▼</p> | <p>Boiler setting screen #6 is used to adjust the freeze protection start temperature parameter. Screen #7 is to select between a low water cutoff device and a flow switch to prevent running the burner without adequate water or flow. Screen #8 is used to increase the blower post purge time for instances where unusual conditions require a longer post purge.</p> <table border="1"> <thead> <tr> <th>Parameter</th> <th>Minimum</th> <th>Default</th> <th>Maximum</th> </tr> </thead> <tbody> <tr> <td>Freeze Protection Start Temp.</td> <td>45°F (7°C)</td> <td>50°F (10°C)</td> <td>56°F (13°C)</td> </tr> <tr> <td>Blower Post Purge</td> <td>30 sec.</td> <td>30 sec.</td> <td>120 sec.</td> </tr> <tr> <th>Parameter</th> <th colspan="2">Choices</th> <th>Default</th> </tr> <tr> <td>Safety Function</td> <td>Low Water Cutoff</td> <td>Flow Switch</td> <td>Low Water Cutoff</td> </tr> </tbody> </table> | Parameter | Minimum | Default | Maximum | Freeze Protection Start Temp. | 45°F (7°C) | 50°F (10°C) | 56°F (13°C) | Blower Post Purge | 30 sec. | 30 sec. | 120 sec. | Parameter | Choices | | Default | Safety Function | Low Water Cutoff | Flow Switch | Low Water Cutoff |
|---|--|-------------|------------------|-------------|---------|-------------------------------|------------|-------------|-------------|-------------------|---------|---------|----------|-----------|---------|--|---------|-----------------|------------------|-------------|------------------|
| Parameter | | Minimum | Default | Maximum | | | | | | | | | | | | | | | | | |
| Freeze Protection Start Temp. | | 45°F (7°C) | 50°F (10°C) | 56°F (13°C) | | | | | | | | | | | | | | | | | |
| Blower Post Purge | 30 sec. | 30 sec. | 120 sec. | | | | | | | | | | | | | | | | | | |
| Parameter | Choices | | Default | | | | | | | | | | | | | | | | | | |
| Safety Function | Low Water Cutoff | Flow Switch | Low Water Cutoff | | | | | | | | | | | | | | | | | | |
| <p>BOILER SETTINGS 7 ▲ Additional Safety Functions LowWaterCO ▼</p> | | | | | | | | | | | | | | | | | | | | | |
| <p>BOILER SETTINGS 8 ▲ Blower Post Purge Time 30 sec ▼</p> | | | | | | | | | | | | | | | | | | | | | |

SERVICE NOTIFICATION

```
SERVICE 1
Reset Notification
Timer / Counters
Press Select: Reset ▼
```

Sample Alert Screen - Flashing "SERVICE" is displayed

```
SERVICE 16:36
STANDBY
Tank: 125 °F
```

```
SERVICE 2 ▲
Notification on:
OFF ▼
```

```
SERVICE 3 ▲
Notification
After: 4000 HRS ▼
```

```
SERVICE 4 ▲
Notification
After: 20000 CYC ▼
```

```
SERVICE 5 ▲
Notification on:
00 - - - 2000 ▼
```

To alert customers for routine service, the PureFire control can be set to display a blinking SERVICE message at the top of the display screen. Screen #1 is used to reset the notification timer/counter. Pressing the **Select** key will reset the notification value and display "Done" in place of reset, providing feedback that the action has been performed. Screen #2 allows selection of notifications on hours, cycles or a specific date. The default value for screen #2 is "OFF", indicating that no notification will occur. The ranges and defaults of values for screen #3 & #4 are shown below.

| Parameter | Minimum | Default | Maximum |
|-------------|---------|---------|---------|
| Hours (#3) | 0 | 4,000 | 8,000 |
| Cycles (#4) | 0 | 20,000 | 50,000 |

Screen #5 shows notification on a specified date. Pressing the **Select** key initiates flashing of the day field. Use the **↑** and **↓** keys to select the desired day of the month. Press **Select** again and the three digits representing the month will begin to flash. Use the **↑** and **↓** keys to select the desired month. Finally, press **Select** again to change the year. If "Notification on:" in screen #2 is set to "Date", the SERVICE indication will appear and begin flashing on the date selected.

SYSTEM TEST

```
SYSTEM TEST
→ Off
Low Power
Ignition Power
Maximum Power
```

```
SYSTEM TEST 16:36
DOMESTIC HOT WATER
1% Tank: 125 °F
```

Using system test, the boilers can be operated at a consistent input rate (low power, ignition or high power) for up to 60 minutes. This is useful for commissioning or troubleshooting purposes. In DHW Mode 1, the tank temperature must be below the target setpoint. In DHW Mode 2, there must be a call for heat in order for the boiler to operate. When operating in system test, the boiler will modulate to prevent exceeding the boiler supply target temperature. All safety functions remain in effect to prevent the boiler from running in an unsafe condition.

| CASCADE | |
|--|--|
| CASCADE Address Selection Boiler Address : 0 ▼ | <p>Up to 8 boilers can be operated as a single system using a cascade control strategy. In this system, the managing boiler starts and sheds dependent boilers as required to meet the demand of the hot water storage system.</p> <p>Boiler Address: To designate a managing boiler, the boiler address is changed from 0 (stand-alone boiler) to 1 (managing boiler). Each dependent boiler is then given an address of 2-8.</p> <p>Start Delay Time: After the lead boiler (not necessarily the managing boiler) is activated, this value determines how quickly each successive boiler is allowed to start if the tank is below the target setpoint and all the operating boilers are above the <i>next boiler start rate</i>.</p> <p>Stop Delay Time: When all boiler input drops below the <i>next boiler stop rate</i> a boiler is shed from the cascade system. After the stop delay time, an additional boiler is shed until all boilers are off. If the storage tank reaches its setpoint plus the <i>stop boiler differential</i>, all boilers will stop.</p> <p>Calculated Setpoint Max Offset Up: In the PureFire cascade system, the managing boiler provides a target setpoint for each dependent boiler. To ensure that the tank setpoint can reach the desired target, the control my offset the dependent boiler supply setpoints to meet the demand. This value limits the maximum amount the dependent boiler can be offset above the system target.</p> <p>Calculated Setpoint Max Offset Down: Similarly, the control can offset the supply setpoint of the individual dependent boilers in order to prevent overshooting the storage tank target temperature.</p> <p>Rotation Interval: This value controls the frequency with which the lead boiler is rotated. A value of 0 keeps the starting sequence in the order of boiler addresses.</p> |
| CASCADE ▲ Start Delay Time : 10 sec ▼ | |
| CASCADE ▲ Stop Delay Time : 1 min ▼ | |
| CASCADE ▲ Stop Boiler Diff : 18 ° F ▼ | |
| CASCADE ▲ Calculated Setpoint Max offset up : 18 ° F ▼ | |
| CASCADE ▲ Calculated Setpoint Max offset down : 9 ° F ▼ | |
| CASCADE ▲ Next Boiler Start rate : 25 % ▼ | |
| CASCADE ▲ Next Boiler Stop rate : 9 % ▼ | |
| CASCADE ▲ Rotation Interval 5 Days ▼ | |

| Parameter | Minimum | Default | Maximum |
|--------------------------|-------------|-------------|-------------|
| Boiler Address | 0 | 0 | 8 |
| Start Delay Time | 10 sec. | 10 sec. | 240 sec. |
| Stop Delay Time | 1 min. | 1 min. | 15 min. |
| Stop Boiler Differential | 1°F (0.5°C) | 18°F (10°C) | 23°F (13°C) |
| Calc. SP Max Up | 0°F (0°C) | 18°F (10°C) | 45°F (25°C) |
| Calc. SP Max Down | 0°F (0°C) | 9°F (5°C) | 36°F (20°C) |
| Next Boiler Start Rate | 0% | 25% | 15% |
| Next Boiler Stop Rate | 9% | 9% | 95% |
| Rotation Interval | 5 Days | 5 Days | 200 Days |

| DEFAULT SETTINGS | |
|--|--|
| D E F A U L T 1 F a c t o r y D e f a u l t s P r e s s S e l e c t : R e s e t ▼ | To reset all the menu parameters back to the factory default values, press Select on default screen #1. All of the values will then appear as the default values as they are displayed in the Appendices. To save values as set up on the site, press Select on default screen #2. After this, any subsequent changes to menu values can be easily reversed by choosing Select on default screen #3. |
| D E F A U L T 2 ▲ S a v e S i t e D e f a u l t s P r e s s S e l e c t : S a v e ▼ | |
| D E F A U L T 3 ▲ S i t e D e f a u l t s P r e s s S e l e c t : R e s e t | |

APPENDIX D. COMBUSTION TEST RECORD

PureFire Combustion Test Record

| | | | |
|--|--|--|--|
| Contact: | | | |
| Company Name: | | | |
| Address: | | | |
| Phone Number: | | | |
| Fax Number: | | | |
| Email Address: | | | |
| Jobsite Data | | | |
| Job Name: | | | |
| Jobsite Address: | | | |
| Boiler Data | | | |
| Boiler Model: | | Boiler Serial No.: | |
| Manufacture Date: | | Startup Date: | |
| Gas Pressure | | | |
| Static Inlet Gas Pressure (in. w.c.) [With Boiler Off]: | | Inlet Gas Pressure Drop After Boiler Startup (in. w.c.): | |
| High Fire Outlet Gas Pressure (in. w.c.): | | Low Fire Outlet Gas Pressure (in. w.c.): | |
| Combustion Readings | | | |
| Flame Signal High Fire (μ A): | | Flame Signal Low Fire (μ A): | |
| CO ₂ High Fire (%): | | CO ₂ Low Fire (%): | |
| CO High Fire (ppm): | | CO Low Fire (ppm): | |
| Fan Speed High Fire: | | Fan Speed Low Fire: | |
| Excess Air High Fire (%): | | Excess Air Low Fire (%): | |
| Exhaust Temperature High Fire (°F): | | Exhaust Temperature Low Fire (°F): | |
| System Information | | | |
| Water Pressure: | | Condensate Line Size: | |
| Vent Length (Total Equivalent Feet): | | Vent Diameter: | |

PEERLESS[®] PUREFIRE[®] PFW[™] SERIES

Gas Hot Water Supply Boilers

PFW-200 PFW-399

Installation, Operation & Maintenance Manual

TO THE INSTALLER:

This manual is the property of the owner and must be affixed near the boiler for future reference.

TO THE OWNER:

This boiler should be inspected annually by a Qualified Service Agency.



PeerlessBoilers.com

PB HEAT, LLC
131 S. CHURCH STREET • BALLY, PA 19503